

VSR Vertical Stack Rail System

PRODUCT USER MANUAL

contents

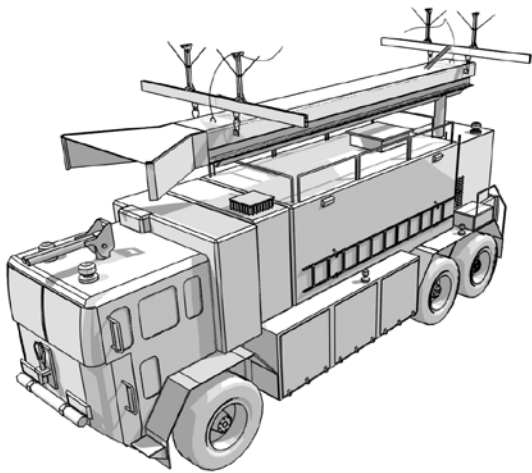

1. Important safety instruction	2
2. Introduction	2
3. Product description	2
4. Safety.....	3
5. Area of use.....	4
6. Delivery.....	4-6
7. Mounting instructions.....	7-16
Measure the mounting height.....	7-8
Catcher and connection socket.....	9
Measurement procedure	10
Support bracket and splicing the profile	11
Mounting rubber seal	12
Lifting the rail	13
Safety wires.....	13
Hose connection	14
Stack adapter.....	15
Pc-500 mounting procedure.....	16
8. Maintenance	17-18
9. Spare part list.....	19-20

Thank you for buying a Plymovent product. Before you unpack and put it into operation please read this product manual carefully, and follow the instructions.

This manual should be handed over and kept by the service department after the installation.

Sales office
Plymovent AB
Kopparbergsgatan 2
SE-214 44 MALMÖ
SWEDEN
Tel: +46 40 30 31 30
Fax: +46 40 30 31 40

England
Plymovent Ltd
Marley Way, Southam Road
Banbury, OX16 2RA, England
Tel: + 44 1295 25 93 11
Fax: + 44 1295 27 17 50
info@plymovent.ca

Canada
Plymovent Inc
24- 1200 Aerowood Dr
Mississauga, On L4W 2S7, Canada
Tel: +1 (905) 564-4748
Fax: +1 (905) 564-4609
info@plymovent.ca

USA
Plymovent Corp.
115 Melrich Road
Cranbury, New Jersey 08512, USA
Tel. + 1 609 395 3500
Fax. + 1 609 655 0919
info@plymovent.com

I. IMPORTANT SAFETY INSTRUCTIONS

Please read these instructions before installing the Vertical Stack Rail System (hereafter called VSR) . This will help you obtain the full benefit from the exhaust removal system you have selected.

- A. Read the Product user manual and Safety Instructions carefully. Failure to follow these instructions could cause a malfunction in the system or unsatisfactory performance.
- B. Follow a regular service and maintenance schedule for efficient operation.

PREFACE

Using this manual

This manual is intended to be used as a work of reference for professional, well trained and authorized persons / user's to be able to safely install, use, maintain and repair the product mentioned on the cover of this document.

Pictograms and symbols

The following pictograms and symbols are used in this manual:

	ATTENTION A remark with additional information for the user. A remark brings possible problems to the user's attention.
--	--

	CAUTION! Procedures, if not carried out with the necessary caution, could damage the product, the workshop or the environment.
---	--

	WARNING! Procedures which, if not carried out with the necessary caution, may damage the product or cause serious personal injury.
---	--

	WARNING! Denotes risk of electric shock.
---	--

	WARNING! Important warning to prevent fire.
---	---

Service and technical support

For information about specific adjustments, maintenance or repair jobs which are not dealt with in this manual, please contact the supplier of the product. He / she will always be willing to help you.

Make sure you have the following specifications at hand:
- The VSR Product User Manual

2. INTRODUCTION

1.1 Identification of the product

The VSR system is made up out of various different parts which together form the VSR Exhaust Removal System. All these individual parts can be traced back to this Product User manual.

3. PRODUCT DESCRIPTION

The VSR System consist of a strong rectangular aluminium profile with a section area of 280 cm². The underside of the rail is an open area sealed with rubber lips. The profile is hung in two (2) bearing loaded trolleys at each support. The profile is connected to the ducts system by a 160mm/6,3" flexible hose. The front opening of the profile has a V formed catcher to accommodate the stack adapter, mounted on the vertical exhaust pipe. The exhaust cone converts the round shape of the exhaust pipe to be flat without changing the section area.

As the returning fire engine drives in to the station the catcher and the profile align themselves to the exhaust pipe position. This movement is created via the bearing loaded runners sliding in the C profile of the support leg. The C-profile hangs in two adjustable vertical legs mounted to the general roof structure. The support legs allow the VSR to have a lateral movement from two separate points of 2 feet side to side.

As the fire engine drives out of the station the exhaust pipe glides along the profile, between the rubber lips, up to the point the vehicle drives out of the station.

A spring is connected between the support legs C-profile and aluminium profile to move the rail into its central rest position. The VSR System is equipped with safety wires capable of carrying the complete system.

As the vehicles continue into the station, the exhaust pipe glides along the rubber sealed profile until the vehicle is parked. All of the poisonous exhaust gases being contained in the profile under vacuum, to be extracted by a fan to the outside of the building. Upon a call-out, the vehicles glide out of the profile in a similar way, and the track resumes it's natural position by the use of mounting springs.

4. SAFETY

General

The manufacturer does not accept any liability for damage to the product or personal injury caused by ignoring of the safety instructions in this manual, or by negligence during installation, use, maintenance, and repair of the product mentioned on the cover of this document and any corresponding accessories.

Specific working conditions or used accessories may require additional safety instructions. Immediately contact your supplier if you detect a potential danger when using the product. The user of the product is always fully responsible for observing the local safety instructions and regulations. Please observe all applicable safety instructions and regulations.

User manual

- Everyone working on or with the product, must be familiar with the contents of this manual and must strictly observe the instructions herein. The management should instruct the personnel in accordance with the manual and observe all instructions and directions given.
- Never change the order of the steps to perform.
- Always keep the manual with or near the product.

Pictograms and instructions on the product (if present)

- The pictograms, warning and instructions attached to the product are part of the safety features. They must not be covered or removed and must be present and legible during the entire life of the product.
- Immediately replace or repair damaged or illegible pictograms, warnings and instructions.

Users

- The use of this product is exclusively reserved to authorized, trained and qualified users. Temporary personnel and personnel in training can only use the product under supervision.

Intended use

The product has been designed as an exhaust removal system. Using the product for other purposes is considered contrary to its intended use. The manufacturer accepts no liability for any damages or injury resulting from such use. The product has been built in accordance with state-of-the-art standards and recognized safety regulations. Only use this product when in technical perfect condition in accordance with its intended use and the instructions explained in the user manual.

Technical specifications

The specifications given in this manual must not be altered.

Modifications

Modifications of (parts of) the system / product is not allowed.

WARNING



Do not attempt installation of this system unless you are familiar with the necessary tools, equipment, utility connections and potential hazards. Installation should be performed only by a qualified service provider. Failure to do so could result in reduced performance of the unit, serious personal injury or death.

WARNING



PRODUCT MAY CONTAIN SHARP EDGES
Use care when servicing and installing the system. Failure to do so could result in minor personal injury.

General information and installation

- Inspect the product and check for damages. Verify the functioning of the safety features.
- Check the working environment. Do not allow unauthorized persons to enter the working environment.
- Protect the product against water and humidity.
- Use common sense. Stay alert and keep your attention to your work. Do not use the product when you are under the influence of drugs, alcohol or medicine.
- Make sure the room is always sufficiently ventilated; this applies especially to confined spaces.
- make sure the product does not block any entrances and exits which must be used for emergency services.
- Make sure that the workshop, in the vicinity of the product, contains sufficient approved fire extinguishers if any electronics, such as control boxes, are used.

Service, maintenance and repairs

- Observe the maintenance intervals given in this manual. Overdue maintenance can lead to high costs for repair and revisions and can render the guarantee null and void.
- Always use tools, materials, lubricants and service techniques which have been approved by the manufacturer. Never use worn tools and do not leave any tools in or on the product.
- Safety features which have been removed for service, maintenance or repairs, must be put back immediately after finishing these jobs and it must be checked that they still function properly.

ATTENTION!



Maintenance should only be performed by authorized, qualified and trained persons (skilled) using appropriate work practices.

5. Area of use

The VSR system is used in fire and rescue stations on vehicles with vertical (top) exhaust pipes. The system can be applied to single or multiple lines of vehicles per bay and also for "drive through systems".

Method of Operation.

An automatic, mechanical exhaust gas extraction system, specially designed for fire and rescue vehicles with top exhaust pipes. The system is used to remove the poisonous petrol and diesel gas fumes direct at the emission source, the exhaust pipe.

When the vehicles reverse or drive in to the fire station, a "catcher" box picks up on the special tapered connection on the vertical exhaust pipe, aligning itself on the aluminium profile both upwards and sideways.

As the vehicles continue into the station, the exhaust pipe glides along the rubber sealed profile until the vehicle is parked. All of the poisonous exhaust gases being contained in the profile under vacuum, to be extracted by a fan to the outside of the building.

Upon a call-out, the vehicles glide out of the profile in a similar way, and the track resumes its natural position by the use of mounting springs.



ATTENTION

The VSR System is designed to operate under standard vehicle performance conditions. Re-generation is not considered to be a standard vehicle performance condition.

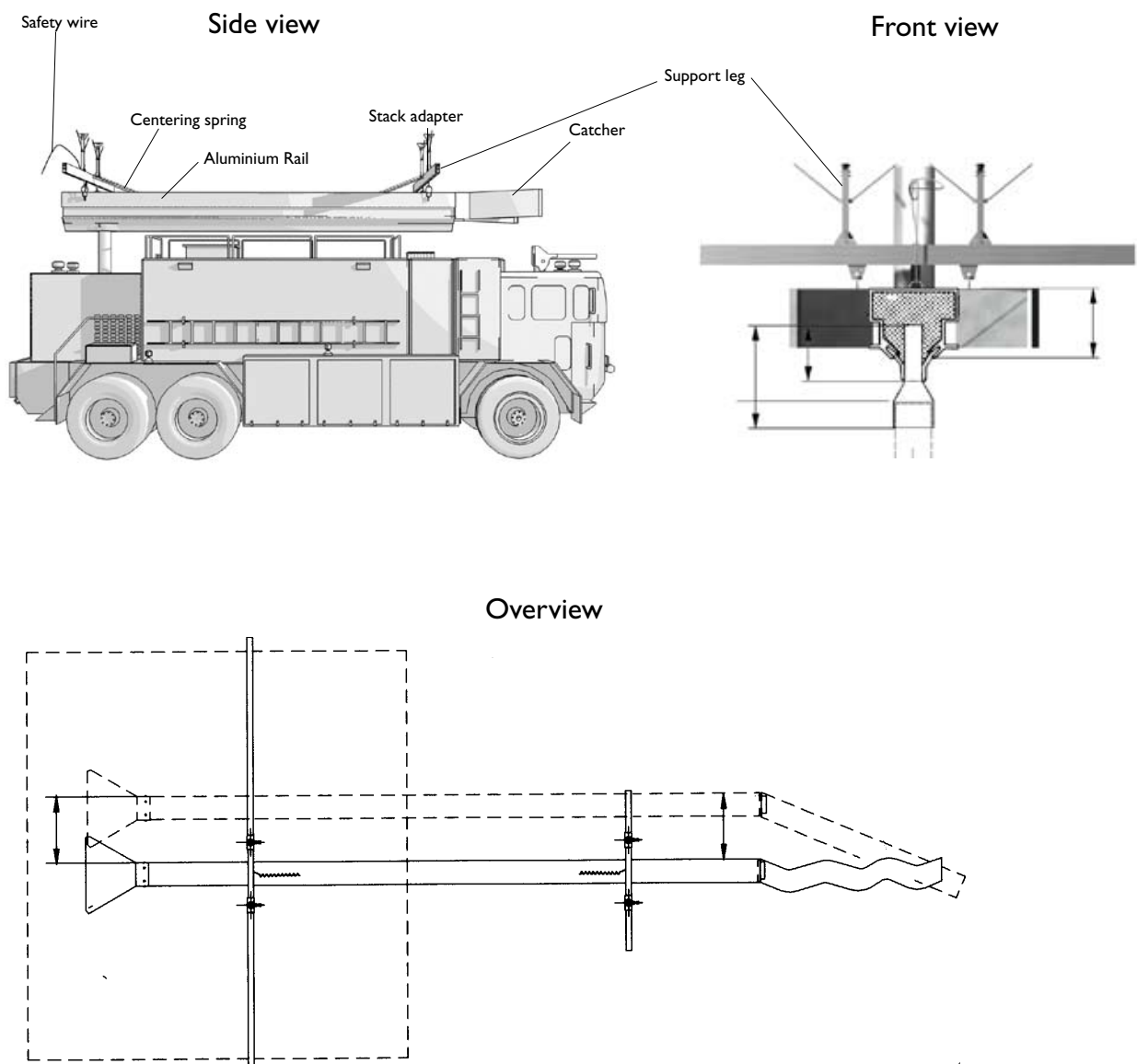

The VSR, in all different versions, is built out of a few standard components which will be described in this section.

Support leg

The aluminium support leg is used for both vertical and horizontal mounting. The standard length is 19' (5790 mm) and it has to be cut to proper lengths.

The dimension is 2" x 2" x 0,1" (50x50x2,5 mm).



Prod. SBT-SL

Side brace

There are three different lengths available, 20" (500 mm), 30" (750 mm) and 6' (1800 mm). The brace can be mounted separately or in pairs using the same brackets.

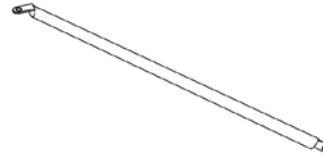

Prod. SBT-SB-S, 20"/ 500mm
Prod. SBT-SB-M, 30"/ 750mm
Prod. SBT-SB-L, 6' / 1800mm

Side brace clamp kit

The kit includes two aluminium brackets for one or two side braces.

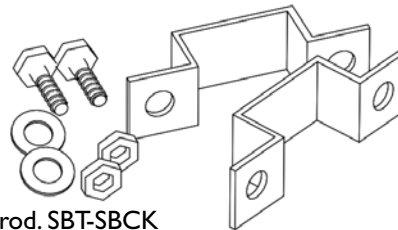

Prod. SBT-SBCK

Adjustable mounting kit (vertical)

The two brackets are exactly the same. They can also be used if the roof is angled and they can be mounted in both directions.

Maximum angle is 30 degrees.

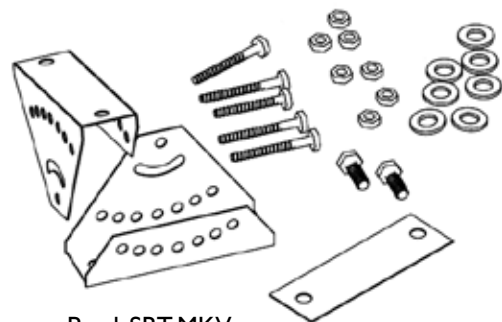

Prod. SBT-MKV

VSR Extraction rail

The VSR-track is 5,8m/19ft or ordered by meter

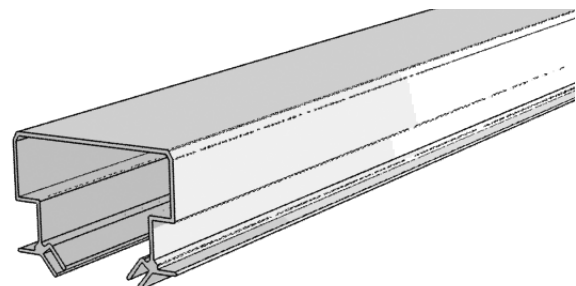

Prod. VSR-Track

The VSR, in all different versions, is built out of a few standard components which will be described in this section.

Drive-through Connection

with top connection, flexible hose 3,1 m/10.2 ft and hose clamps.

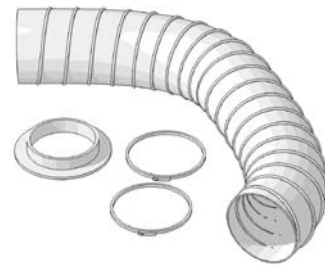

Prod. VSR-DTC

Back-In Connection

with end connection, flexible hose 1,3 m/4.3 ft and hose clamps

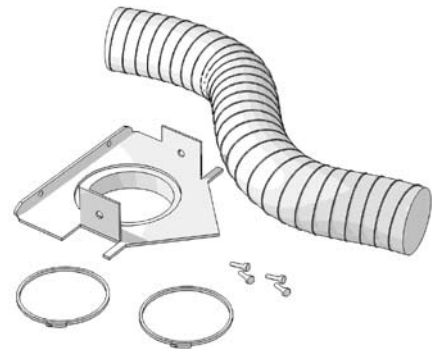

Prod VSR-BIC

VSR-Catcher,

including gate damper.

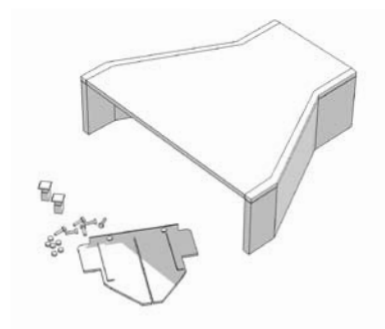

Prod. VSR-CAT

VSR-Kit

consisting of suspension profile, 2 suspension brackets and trolleys, 1 centering spring, safety wire, trolley stops and hardware for one suspension point.

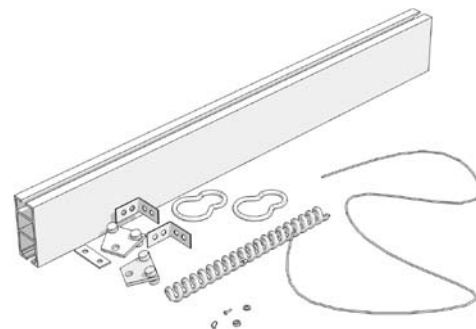

Prod. VSR-SUS

Measure the mounting height

The height of the rail is determined by measuring the distance between the floor and the end of the vehicle exhaust pipe. The measure between the top of the exhaust pipe and the horizontal suspension (VSR-SUS) is 445mm/17,5”.



WARNING

PRODUCT MAY CONTAIN SHARP EDGES
Use care when servicing unit.
Failure to do so could result in minor personal injury.

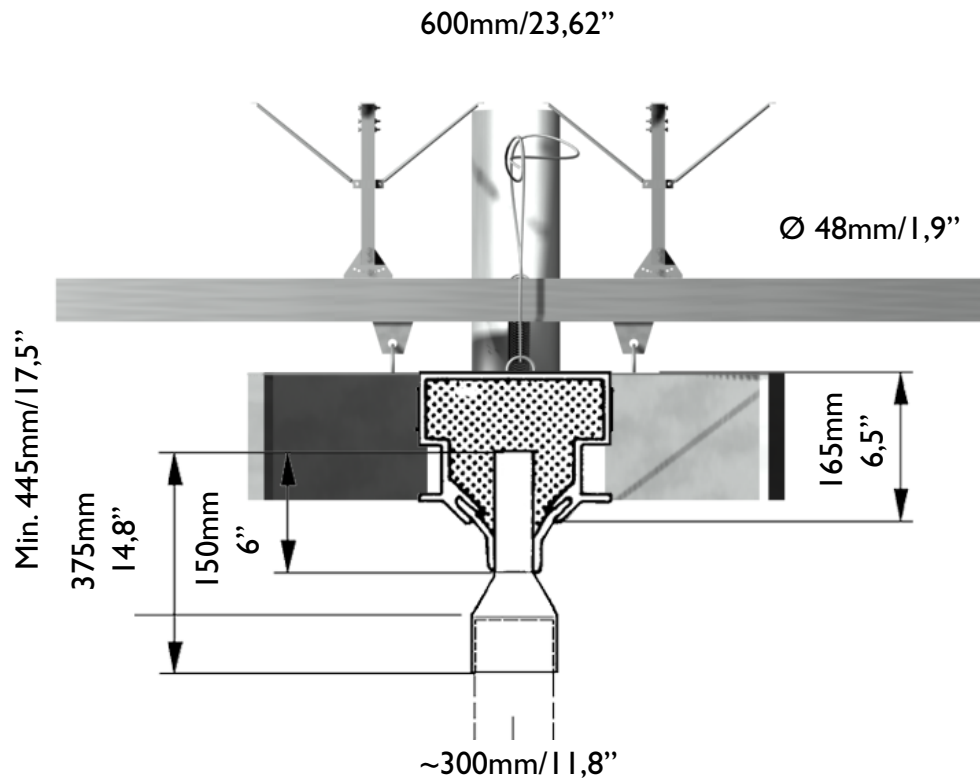

Suspension

This is the standard support for VSR, included in all models.

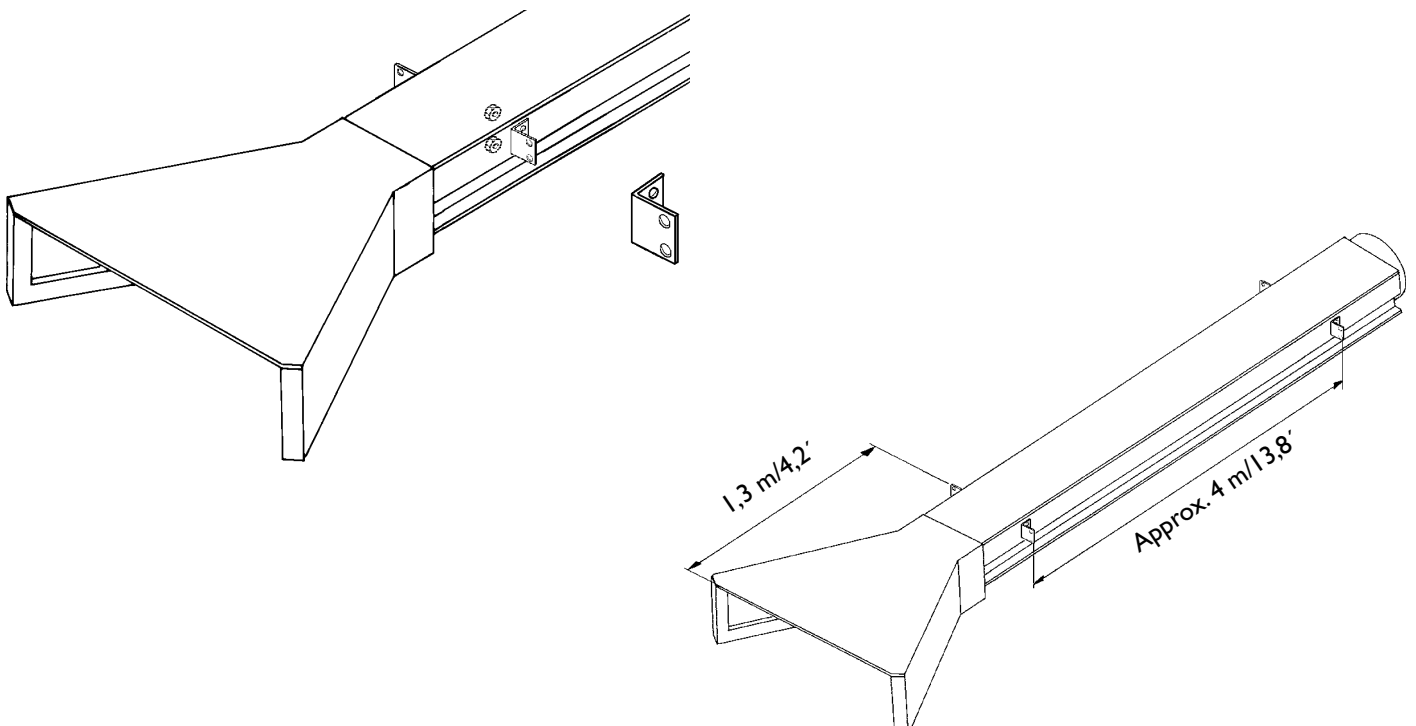

1. VSR rail
2. Catcher
3. Support brackets
4. Horizontal support
5. Vertical support

Put the VSR parts under the rails intended position.

The catcher must be positioned as close as possible to the gate with a safety distance of 50-100 mm/2-4”.

Check and determine the location of the support legs according to the required distances between support legs and the catcher as shown below.

The vertical support pipe (5) is to be slid onto the horizontal support profile (4).
Level the support.

WARNING	
	<p>PRODUCT MAY CONTAIN SHARP EDGES Use care when servicing unit. Failure to do so could result in minor personal injury.</p>

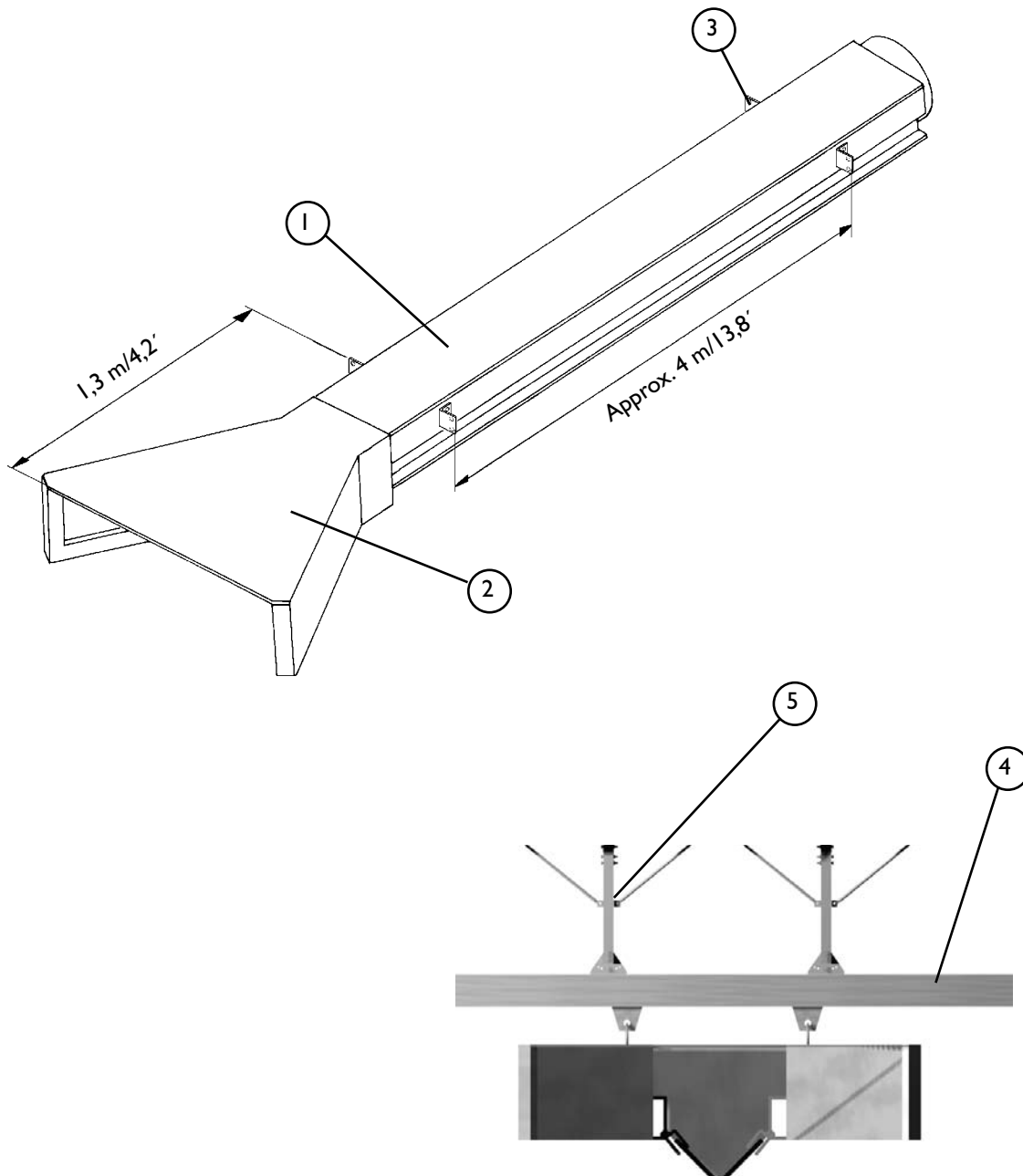

CATCHER AND CONNECTION SOCKET

1. VSR rail
2. Catcher
3. Connection socket, $d=160\text{ mm}/6,3''$

Mount the catcher at the exit end of the rail.

Drill 8.5 mm holes in the profile according to the hole structure on the catcher.

The catcher is to be mounted with 2 pcs M8x25 and 2 pcs M8x45 with nuts.

Mount the connection socket, $d=160\text{ mm}/6,3''$, to the opposite end of the rail with 4 pcs M8x20.

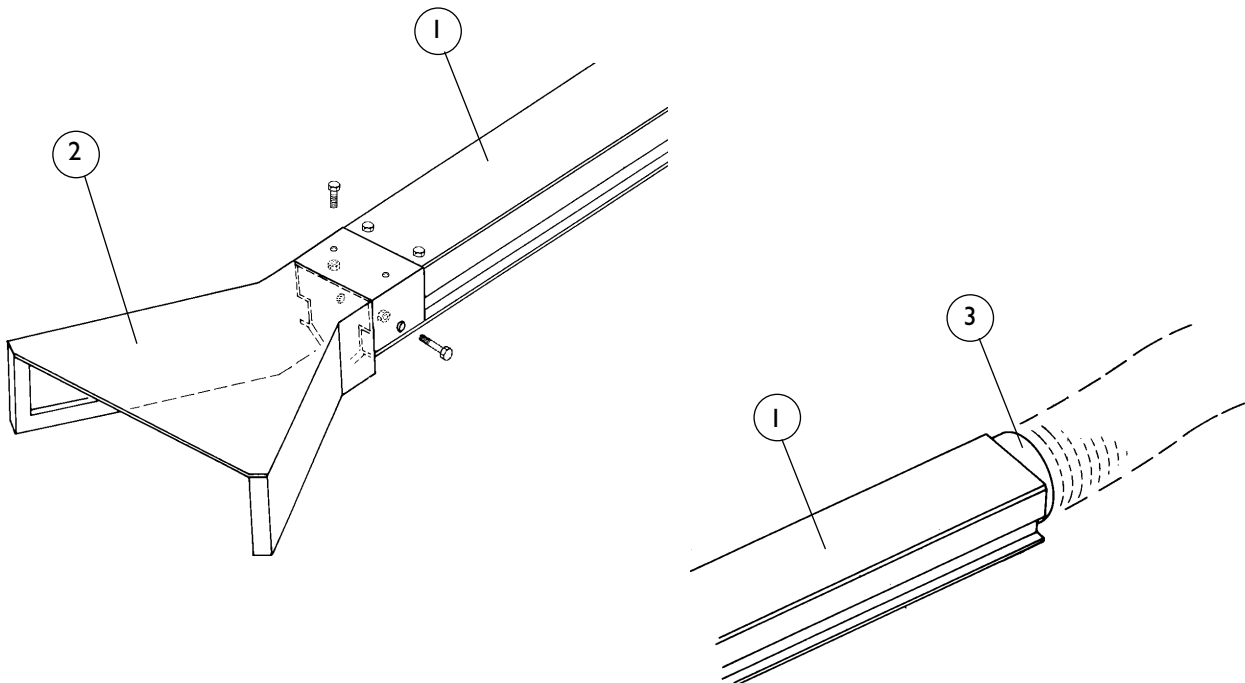
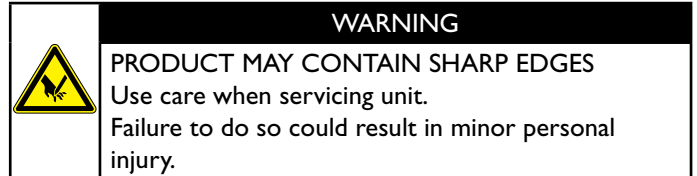

MEASUREMENT PROCEDURES

1. Exhaust pipe
2. Stack adapter
3. Exhaust pipe height
4. Distance between gate and exhaust pipe
5. Distance C/C exhaust pipe and vehicle body.

Back-In

Measure the distance between the gate and the exhaust pipe.

This distance (4) plus 1 m (minimum) is the required length of the rail.

Note! The vehicle must be as far away from the gate as possible in back-in position.

Drive-Through

Measure the distance between the exit and entrance gate. This distance minus 0.5-1.0 m/1,6-3,3' (depending on free space from gate) is the required length of the rail.

The VSR is normally positioned immediately after the gate at a distance of approx. 50-100 mm/2-4".

Check the height of the exhaust pipe, see further under measurement procedures, see next page for required space for exhaust pipe.

The distance C/C exhaust pipe and truck body (5) is the required rail position from the truck body.

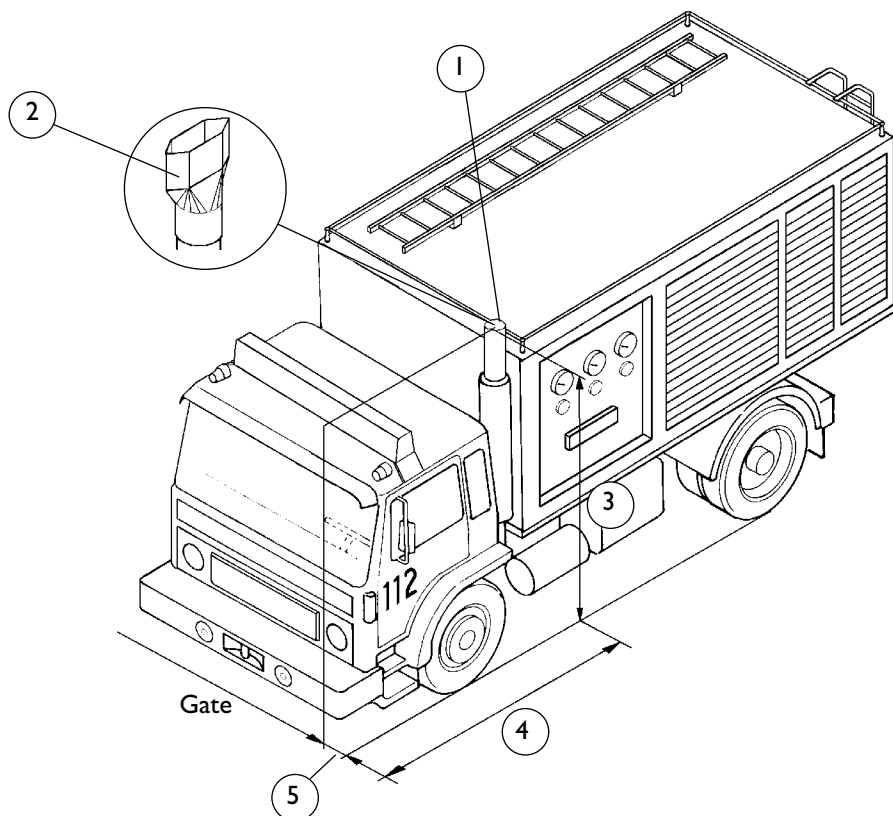
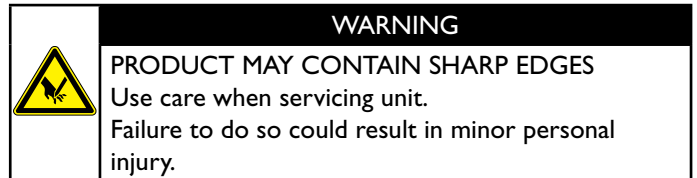

7.

MOUNTING INSTRUCTION

SUPPORT BRACKETS

1. VSR profile
2. Support bracket

The support brackets are to be positioned according to the support measurement procedure. It is important that they are mounted exactly at the support leg position.

Drill 8.5 mm/0,33" holes and bolt together every support bracket with 2 pcs of M8x25 with nuts.

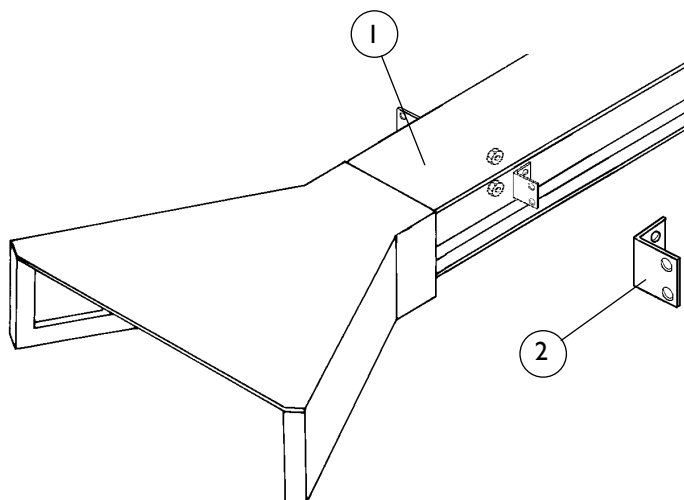
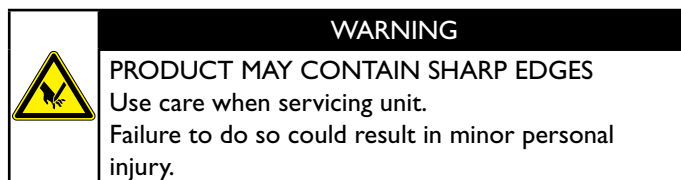

RAIL SPLICE

1. VSR profile
2. Splicing sleeve

Put the rail parts under its intended position on trestles or similar.

Align the profiles vertically and horizontally.

Fix the splicing sleeve with a clamp, drill according to the drawing below with a 8.5 mm/0,33" drill-bit and screw the splicing sleeve to one of the profiles.

Put on the other profile, position the splicing sleeve horizontally and vertically, drill and screw together. Every splicing sleeve is to be bolted together with 12 pcs M8x25.

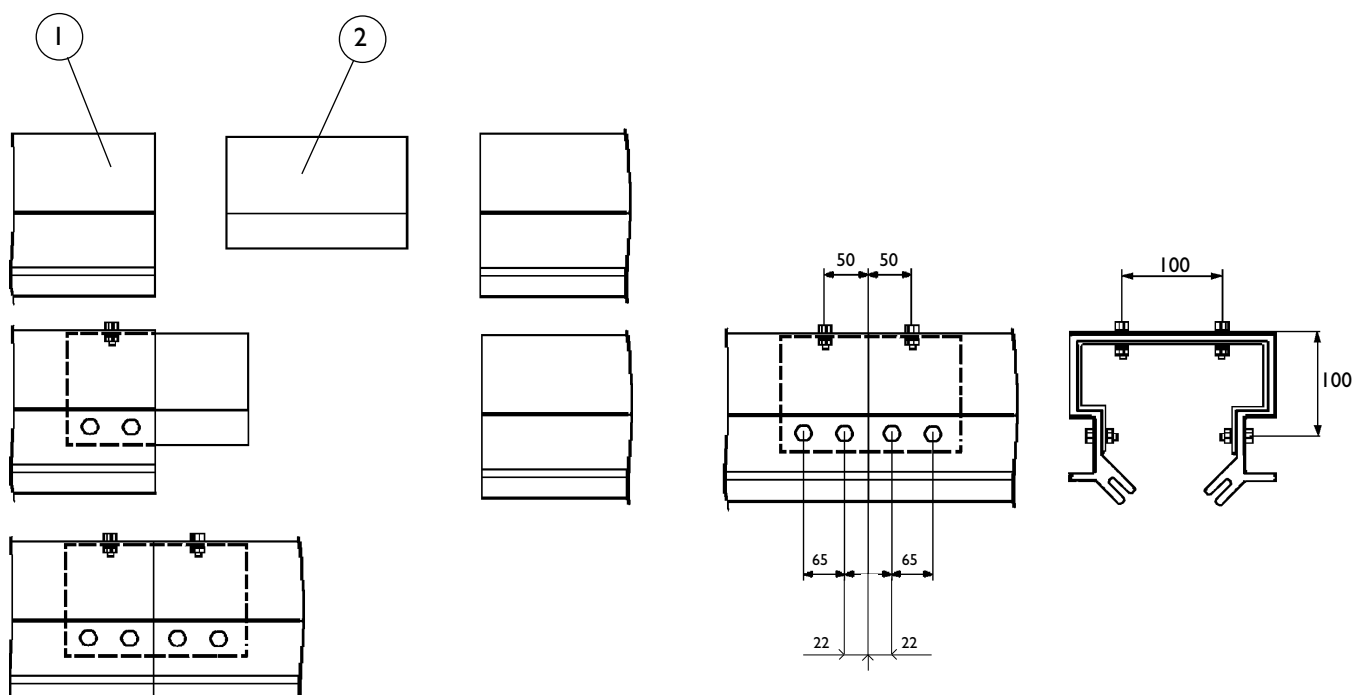

MOUNTING OF RUBBER SEAL

1. VSR profile
2. Rubber seal
3. Tool no. I 1600
4. Tool no. I 1606

Turn the rail profile with the opening upwards.

If the seal must be joined it must be done before mounting. The rubber seal should overlap and be cut together with a sharp knife. The rubber seal ends are to be fixed together with glue; Loctite no. 495 or similar rubber glue.

Note! The rubber seal is to be greased with liquid soap before mounting.

The rubber seal is mounted with tool no. I 1600

The rubber seal is easily mounted with tool no. I 1606, the rail profile hanging in its support legs.

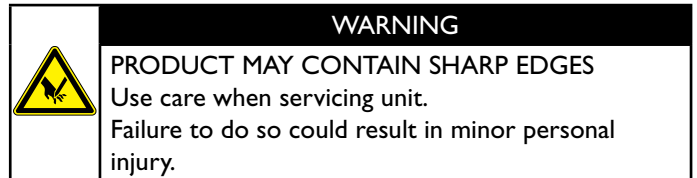

Note! The rubber seal must be angle inward

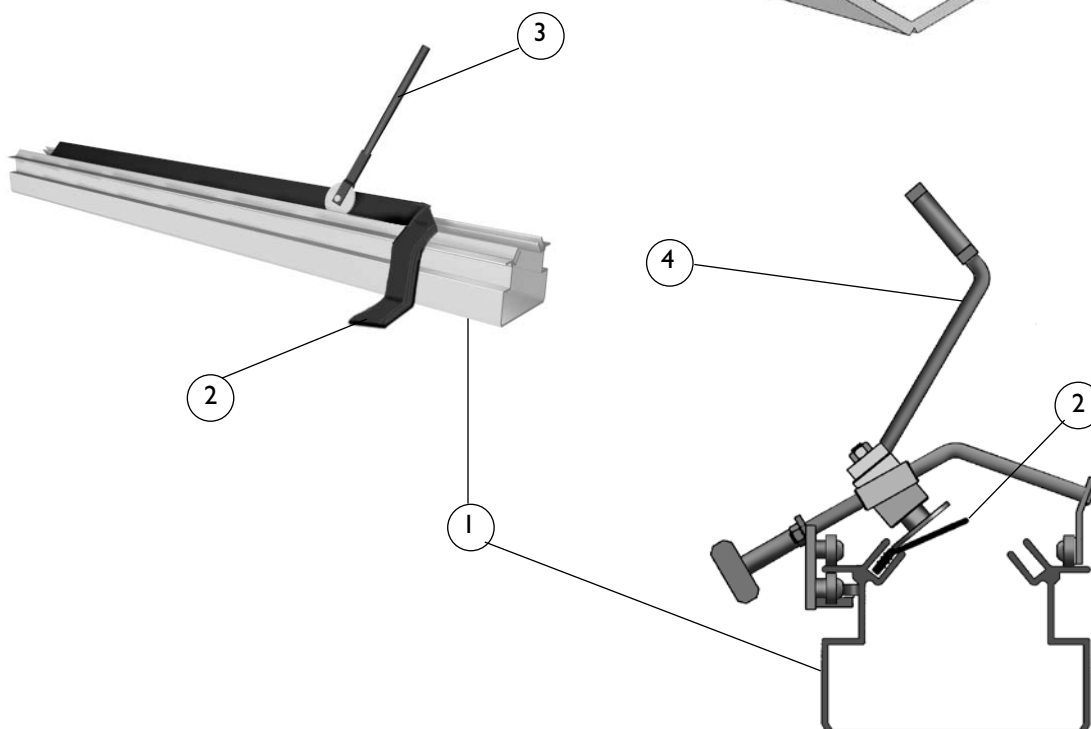
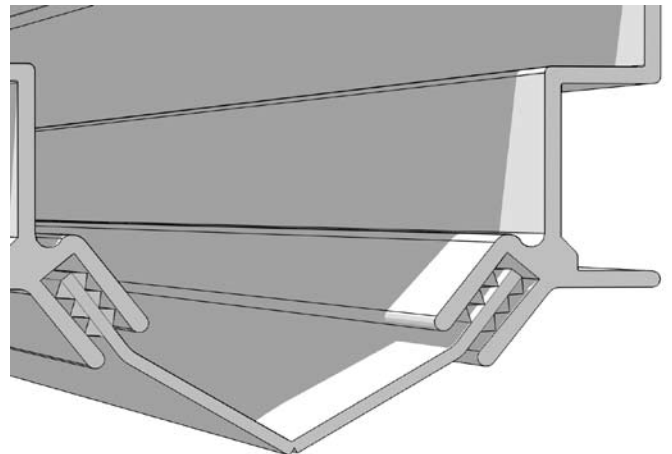

LIFTING THE RAIL

1. VSR profile
2. Support bracket
3. Horizontal support, C-profile
4. Support trolley with safety hook.

Lift the rail with a minimum of lifting points every 10 m/33'. Attach the safety hook of the support trolley to the support brackets according to the picture below.

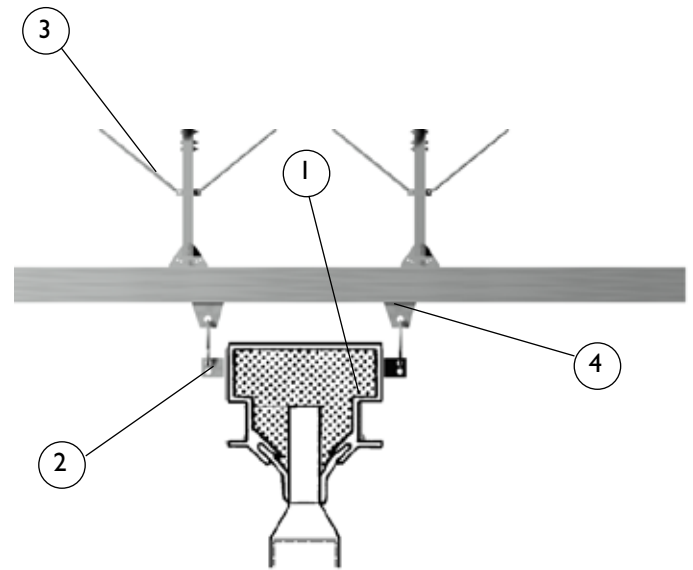

C/C SPRINGS/SAFETY WIRES

1. VSR profile
2. Centering spring
3. Safety wires

Drill a 6.5 mm/0,25" hole, 800 mm/2,6' from the support leg, as shown in the picture below. Screw the M6 eyebolts with M6 nuts into the hole.

Fix the centering spring between the hook on the horizontal support and the eyebolt.

Drill a 8.5 mm/0,33" hole, 100 mm/4" from the support leg as shown in the picture below. Screw the safety eyebolts to the rail with 2 pcs of M8x25.

Mount the safety wires with a wirelock into the safety eyebolts and around the support pipe, as shown below, or around the ceiling beams.

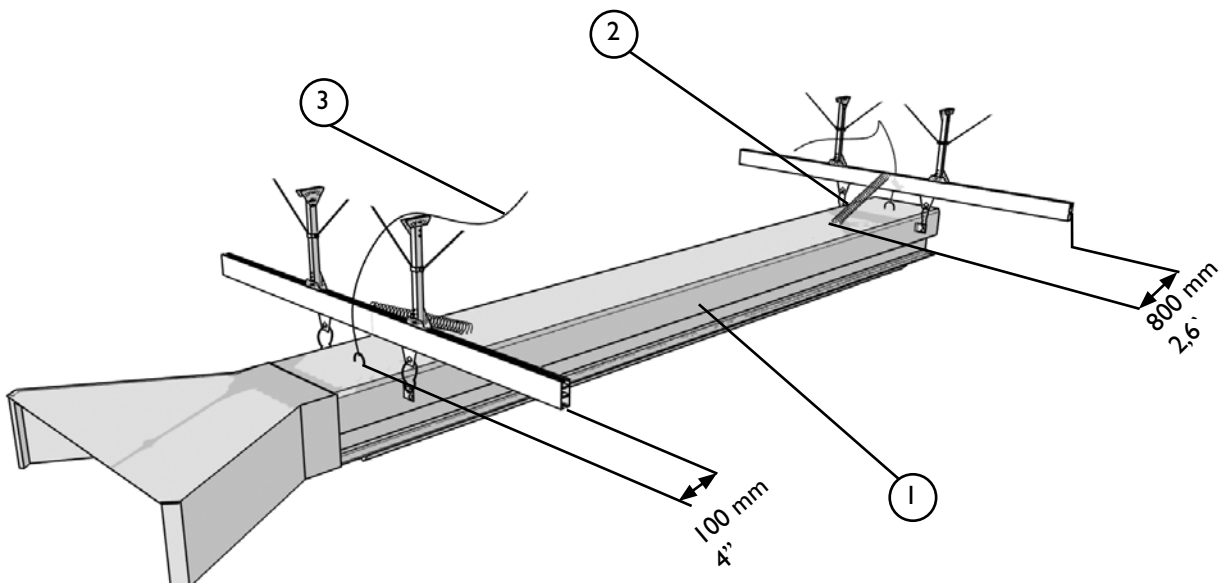

HOSE CONNECTION

1. VSR profile
2. Hose connection, $d=160\text{ mm}/6,3''$, $L=1.3\text{ m}/4,2'$
3. Connection socket, $d=160\text{ mm}/6,3''$

Mount the hose between the connection socket and the duct connection.

The length of the hose must be adjusted so that it reaches the outer side positions of the rail.

VSR systems longer than $18\text{ m}/59'$ should have several connection sockets at the top of the rail.

These must be positioned at an equal distance from one another.

Cut a hole with a diam. of $160\text{ mm}/6,3''$ and fasten the socket with self rivet screws.

Connect the hoses in the same way as the end connection.

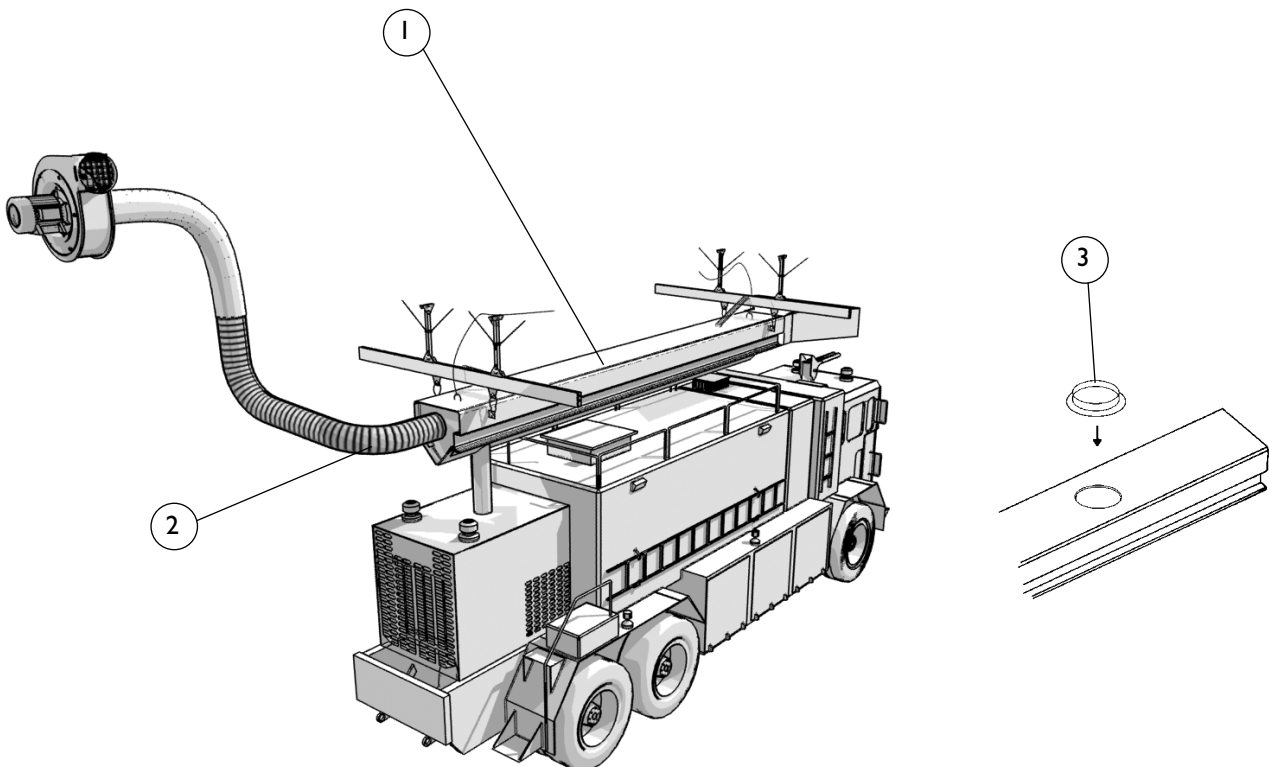

STACK ADAPTER

1. Stack adapter
2. Exhaust pipe

The exhaust pipe must be straight, vertical and cut in a 90° angle to fit the stack adapter.

Mount the stack adapter onto the exhaust pipe and fasten it by tightening the lock bolts.

Note! The distance between the exhaust pipe and the horizontal support leg must be a minimum of 445 mm/17,5". For further information, see support legs measurement.

Final adjustment of the VSR rail and the stack adapter height is to be done when the vehicle drives into the appliance bay.

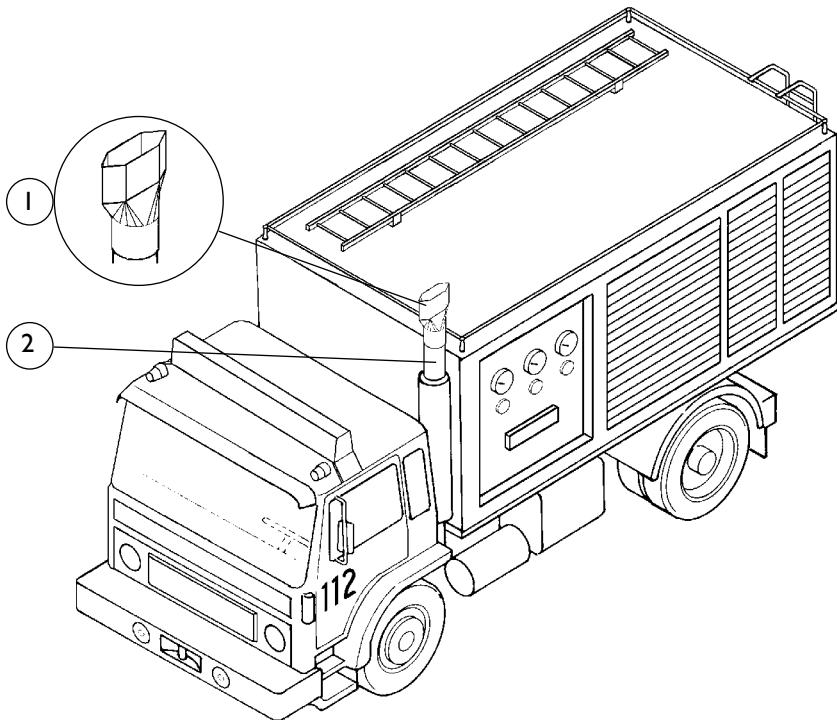

PC-500 MOUNTING PROCEDURE

1. VSR profile
2. PC-500, Pressure controller
3. Drilling machine with 10 mm/0.4" drillbit

Drill a 10 mm/0.4" hole in the VSR profile nearby the crab when the vehicle is in its rest position.

Thread the pressure controller directly into the VSR profile.

Mount a pressure controller the same way at the end of the exit side on the rail, to achieve fan start when the vehicle returns.

Connect the electrical low voltage cables to the pressure controller with accompanying tags.

Further connection to pressure control unit, PCU-1000, see separate electrical diagram.

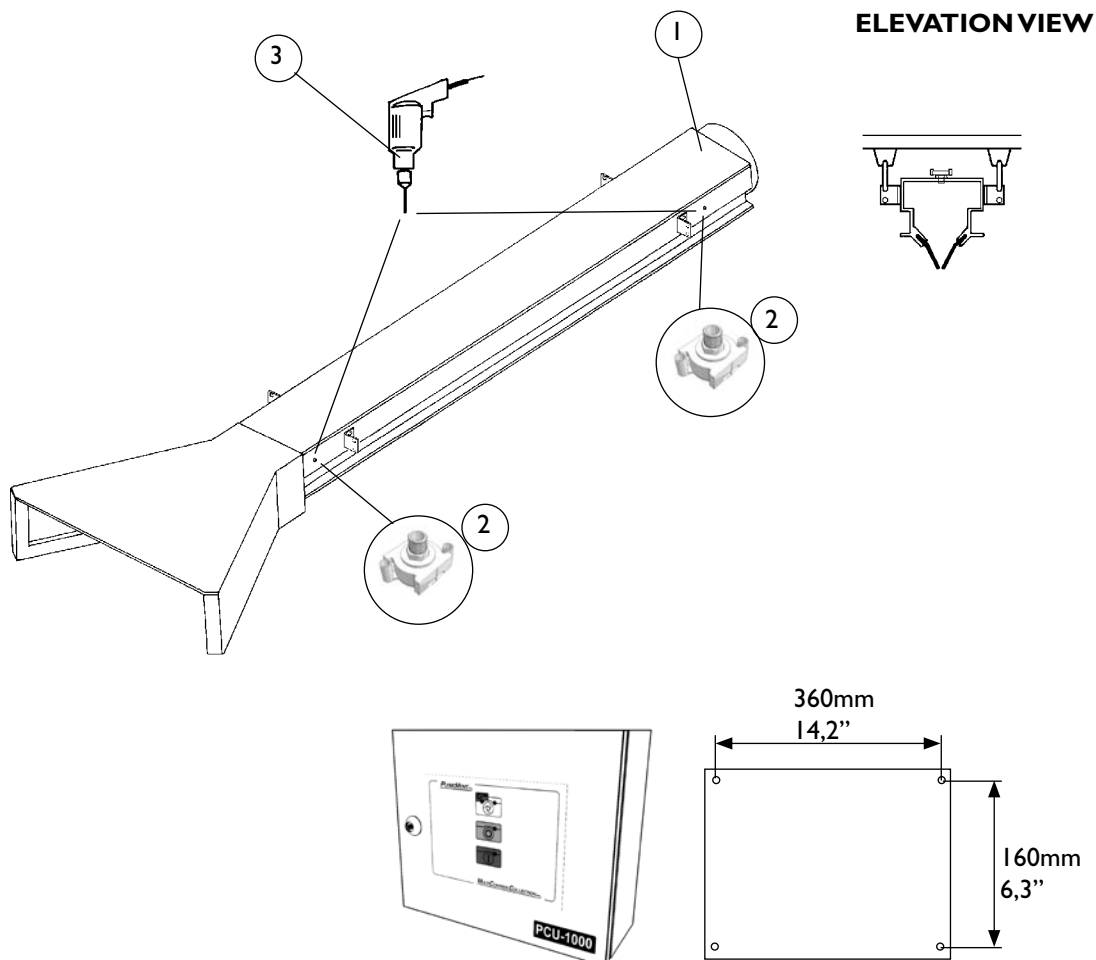

Routine check and maintenance shall be performed according to the following schedule:

0-500	call outs/year	every 16 weeks
500-1500	call outs/year	every 12 weeks
1500-3000	call outs/year	every 8 weeks
3000+	call outs/year	every 4 weeks

1. Clean the inside of the rubber seals
2. Check that the rail runs smoothly in the horizontal support.
3. Check for mechanical damages on support legs, trolleys and safety hooks.

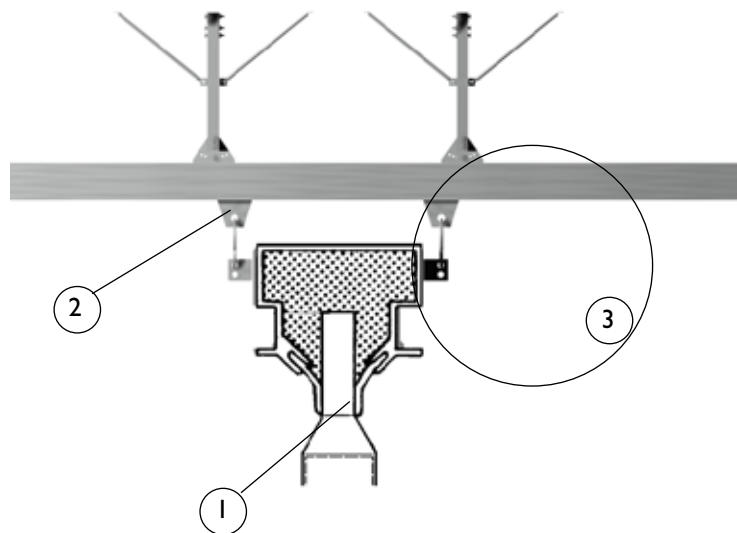

4. Change of rubber seal:

Unscrew the catcher (A) from the VSR profile (B).

Pull off the old rubber seal (C).

Before mounting the new rubber seal they must be greased with liquid soap.

Mount back the catcher (A) on the VSR profile.

5. Trolley change:

Start by dismantling the spring (D).

Unscrew the stopbolt (E) on the horizontal support, C-profile.

Pull carefully the rail to the side until the support trolley (F) appears.

Note! Be careful when pulling the rail to the side to avoid both support trolleys to slide out of the horizontal support leg. Unhook the safety hook (G) from the support trolley and change the support trolley to a new one. Hook the safety hook onto the new support trolley, and push the rail back in the normal position. Refit the stopbolt (E) and the spring (D). Check that the rail moves smoothly in the support.

6. Change of rubber gate (H)

Unscrew the old rubber gate (H).

Mount the new rubber gate in the same position.

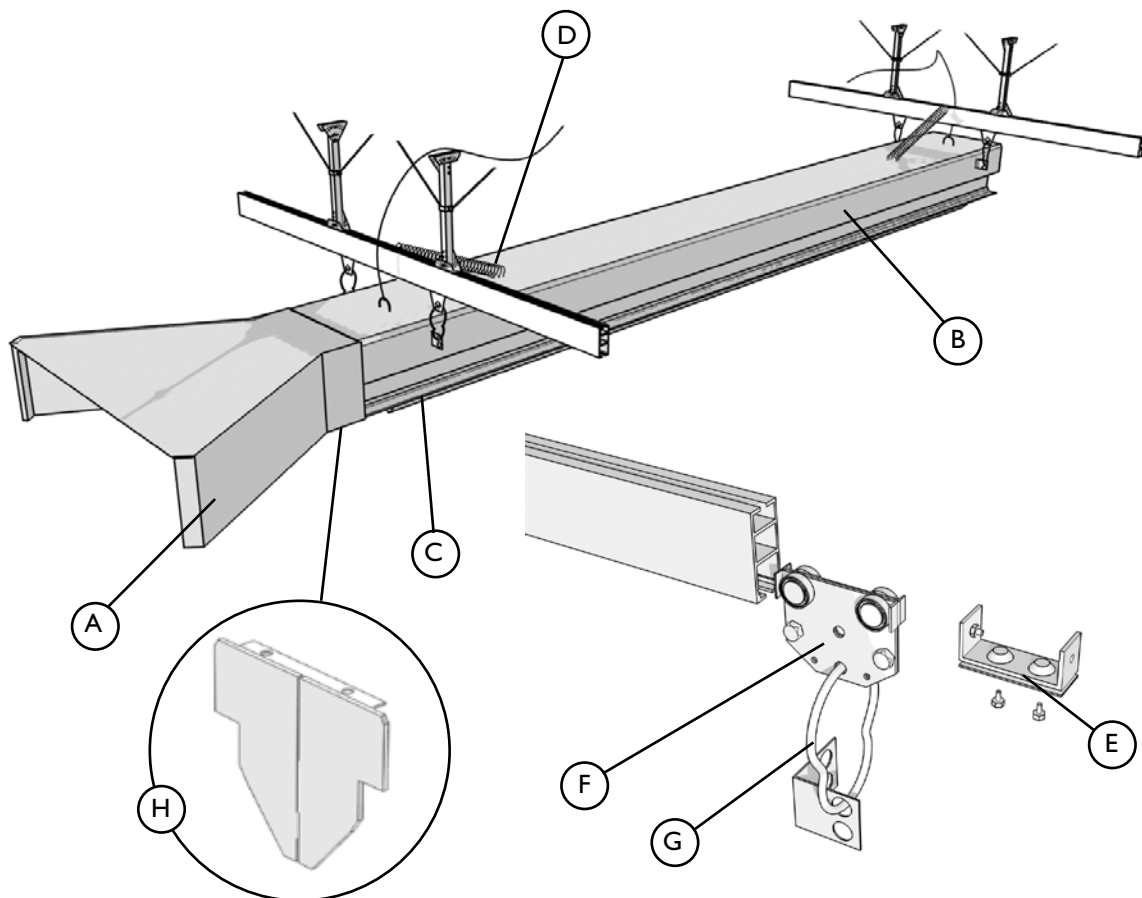

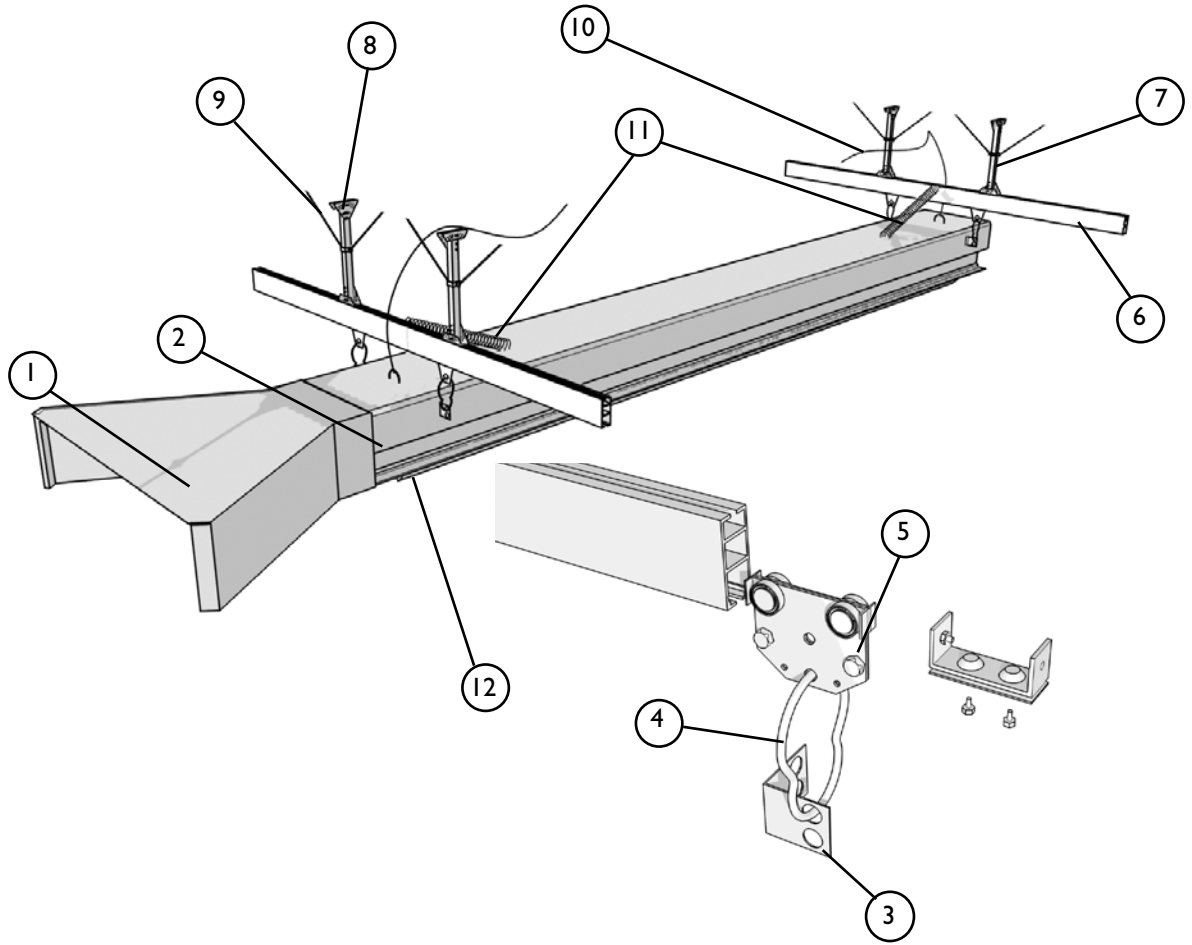

9.

SPARE PARTS

PLYMOVENT®	SPARE PARTS LIST	BSAB No: T3.1 Ser. No: VSR / RR Date: Aug -98 Replace:
VSR-RAILS	© Copyright: All right reserved. All information within this printed matter may not be reproduced, handed over, copied, xeroxed or translated into another language, in any form or any means without written permission from PlymoVent AB. PlymoVent AB reserves the right to make design changes.	

Produkt No:	Description
A	All models
B	VSR-6
C	VSR-9
D	VSR-12
E	VSR-12-D
F	VSR-15
G	VSR-15-D
H	VSR-18
I	VSR-18-D
J	VSR-21
K	VSR-21-D
L	VSR-24
M	VSR-24-D
G	

Abbreviations

- X = Order as required, state required length.
- Y = Depending on ceiling height

Pos	Art. No:	A	B	C	D	E	F	G	H	I	J	K	L	M	Description	Note
1	1-820-DS		1	1	1	2	1	2	1	2	1	2	1	2	Catcher	
2	3-902-DM		1	1	1	2	1	2	1	2	1	2	1	2	Rubber Gate	
3	4-1149		4	6	6	6	6	6	8	8	8	8	10	10	Support bracket	
4	962 530		4	6	6	6	6	6	8	8	8	8	10	10	Safety Hook	
5	4-1378		4	6	6	6	6	6	8	8	8	8	10	10	Support Trolley	
6	516 187		2	3	3	3	3	3	4	4	4	4	5	5	Horizontal SBT-profile L=1,2m	
7	8120-1011	X													Support Leg	
8	8150-1011		4	6	6	6	6	6	8	8	8	8	10	10	Mounting Kit Vertical	
9	8145-1011	Y													Side Brace Kit Short	
9	8146-1011	Y													Side Brace Kit Medium	
9	8147-1011	Y													Side Brace Kit Long	
10	964 155		2	3	3	3	3	3	4	4	4	4	5	5	Safety wire	
11	968 180		2	3	3	3	3	3	4	4	4	4	5	5	Centering Spring	
12	30015	X													Rubber Seal	

When ordering spare parts please quote:
 •Product No. (see label) • Batch No • Description • Part No • Quantity
 For example:
 VSR Support Trolley 4-1378