

**step 110**

## **Operating manual Escalator Cleaning Machine**

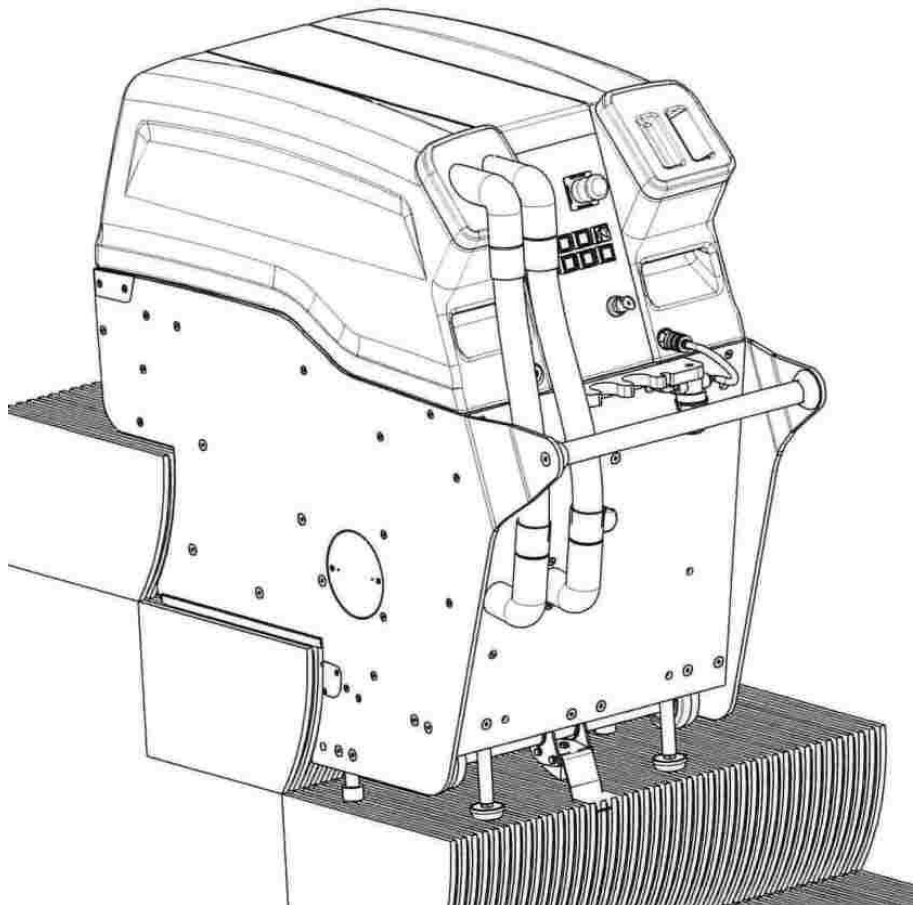

Read these instructions  
carefully before operat-  
ing the machine!



## Table of contents

<b>1</b>	<b>Safety instructions .....</b>	<b>4</b>
1.1	Preliminary remarks .....	4
1.2	Owner's duties.....	4
1.3	Intended and specified use .....	4
1.4	Who may operate the machine?.....	4
1.5	Safety for the operator.....	5
1.6	Modifications and changes to the machine .....	5
1.7	General safety instructions .....	5
1.8	Safety instructions for mains-operated machines .....	5
1.9	Information on the warning signs .....	6
1.10	Warning signs and stickers .....	6
1.11	Product liability.....	6
1.12	Emissions .....	6
1.13	Sources of danger .....	6
1.14	Procedure in case of emergency .....	7
<b>2</b>	<b>Description .....</b>	<b>8</b>
2.1	Technical data.....	8
2.2	List of reference numbers .....	9
2.3	Location of components.....	9
<b>3</b>	<b>Operation .....</b>	<b>11</b>
3.1	Before start-up .....	11
3.2	Assemble brushes.....	11
3.3	Filling fresh water .....	12
3.4	Preparations on site .....	13
3.5	Safety measures on site .....	13
3.6	Preliminary work .....	14
3.7	Working instructions .....	14
3.8	Positioning the machine on escalator .....	14
3.9	Setting step height .....	15
3.10	Select cleaning programmes .....	17
3.10.1	Programm 1: Quick cleaning cycle .....	17

3.10.2	Programm 2: Maintenance cleaning cycle .....	17
3.10.3	Programm 3: Intensive cleaning cycle .....	17
3.11	Cleaning the escalator .....	18
3.12	Subsequent cleaning .....	20
3.13	Refilling with fresh water .....	20
3.14	Emptying the dirty-water tanks.....	21
3.15	Ending the cleaning process.....	22
3.16	Use of transport trolley .....	23
3.16.1	Preparation for transport.....	23
3.16.2	Use of transport trolley for maintenance.....	24
<b>4</b>	<b>Maintenance / Care .....</b>	<b>26</b>
4.1	Safety measures during cleaning and maintenance of the machine .....	26
4.2	Daily care .....	26
4.3	Weekly care .....	26
4.4	Maintenance after 30 service hours .....	26
4.5	Maintenance after 100 service hours .....	27
4.6	Anumal maintenance .....	28
4.6.1	Tightening the chain.....	28
4.6.2	Cleaning and replacing fresh water nozzles.....	29
4.7	Troubleshooting and remedy .....	30
<b>5</b>	<b>Konformitätserklärung.....</b>	<b>Fehler! Textmarke nicht definiert.</b>
<b>6</b>	<b>Notizen.....</b>	<b>32</b>

## 1 Safety instructions

### 1.1 Preliminary remarks

The escalator deep cleaning machine step 100 was manufactured according to state-of-the-art technology and in compliance with all relevant regulations. This, however, does not guarantee that some other unavoidable dangers for persons and property can occur. All personnel working with this machine must therefore read and follow these operating instructions, and in particular the safety regulations, with great care.

These operating instructions must remain at the machine for use by the operator. Each operator must receive thorough instruction on handling and working with the machine.

### 1.2 Owner's duties

In accordance with EU directive on the use of operating equipment 89/655/EEC Art. 6(1) and 7 and EU framework directive 89/391/EEC Art. 1(1) and Art. 6(1), the owner of the equipment is obliged to instruct all persons, particularly with regard to safety, who will be authorised to work on assembly, operation, maintenance, repair or dismantling of the machine.

The owner is also obliged in accordance with EU directive on the use of operating equipment 89/655/EEC Art. 4a to inspect the machine before start-up, following repair work and following faults or malfunction.

### 1.3 Intended and specified use

The escalator deep cleaning machine step 100 is exclusively intended for basic and maintenance cleaning of indoor and outdoor escalators. Any use beyond this stipulation must be considered as contrary to the manufacturer's intentions. The manufacturer will not be liable for any damage resulting from such work; all risk in this case will be borne exclusively by the operator. Correct use of the machine also includes compliance with the conditions of operation and maintenance stipulated by the manufacturer.

- The escalator deep cleaning machine step 100 is not intended nor suitable for cleaning hazardous dirt.
- The machine may only be used with the cleaning liquid approved by the manufacturer.
- The machine is not fire-proof.
- The machine is also not licensed for use in cleaning public streets and paths.

### 1.4 Who may operate the machine?

The machine may only be used by persons who have been instructed in its operation and who are expressly authorised to carry out such work. These persons should be at least 18 years old.

All relevant accident prevention regulations and other generally recognised rules of safety engineering, industrial medicine and the highway code must be strictly observed.

Assembly, equipment, maintenance and repair work demand special knowledge and may only be carried out by specially trained experts.

## 1.5 Safety for the operator

- The user must under no circumstances touch the plug of the power supply with damp hands.
- When the machine is being disconnected from the power network, only the plug itself may be pulled - never the power cable.
- The machine may be repaired or opened only by qualified electricians.



If work on the opened machine with connected current is absolutely necessary, such work may be carried out only by a qualified electrician who is familiar with all attendant dangers and the relevant work stipulations (VDE0100). When work is carried out on machine or parts when live, only tools specially intended for this purpose may be used.

## 1.6 Modifications and changes to the machine

It is forbidden for reasons of safety to carry out modifications to this machine. Any unauthorised modifications to the machine automatically invalidate all liability claims against the manufacturer for any damage caused by the modified machine.

Original parts and accessories have been specially designed for this machine. Parts and fittings made by other manufacturers have not been tested by us and are therefore not approved for use. Assembly and installation of such parts could impair the safety and the perfect functioning of the machine. Columbus expressly refuses to accept liability for any damage resulting from the use of non-original parts and accessories.

## 1.7 General safety instructions

- When the machine is not in use, it must always be locked away and the key removed.  
If it is not possible to lock away the machine, some other suitable measures must be taken to prevent unauthorised use.
- Neither the electrical nor mechanical safety devices on the machine may be changed or put out of action.
- It must be ensured that no other persons, in particular children, are in the vicinity of the machine when it is in operation.
- The machine may only be transported in elevators whose permitted load is adequate for this purpose.

## 1.8 Safety instructions for mains-operated machines

Care must be taken that the mains cable incurs no damage by being crushed, torn, frayed, driven over, etc. This connection must be examined regularly for damage, bare points, scorched areas, etc. The machine may not be used unless the mains connections is in perfect condition. The plug must always be disconnected prior to any cleaning or maintenance work on the machine, or when accessories are being fitted and replaced. When parts, such as brushes, mains connection cables, plugs, etc. are being replaced, all technical data provided by the manufacturer must be observed and only original spare parts used; otherwise safety of the machine could be impaired. If the power cable is damaged, it must be replaced

by a service workshop approved by the manufacturer as special tools are required for such work.

## 1.9 Information on the warning signs

The purpose of the warning signs used in these operating instructions is to emphasise certain sources of danger in the escalator deep cleaning machine step 100.

The following symbols are used in these operating instructions:



Indicates a possibly dangerous situation through contact with parts conducting electricity.

Failure to observe these warnings could lead to death or serious injury.



Indicates a possibly dangerous situation.

Failure to observe such warnings could lead to serious injury.



Indicates special information for optimum use or to facilitate operation of the machine.

## 1.10 Warning signs and stickers



Markings, warning signs and stickers may never be removed!

Damaged or illegible warning signs and stickers must be replaced or repaired immediately!!

## 1.11 Product liability

The operator is expressly notified that the machine must be used only for the intended purpose. If the machine is not used for the intended purpose, such use will be at the sole risk and responsibility of the user.

Columbus will not accept any liability in such cases.

## 1.12 Emissions

The A-assessed equivalent continuous sound level of this machine measures  $78 \pm 2$  dB (A).

## 1.13 Sources of danger

If the operator on the escalator wishes to leave machine, he must lower the machine, i.e. let the machine rest on the glide strip. The machine must then be moved in this lowered position with the escalator to the bottom end of the escalator.



The machine may not be left unattended and unlocked on the escalator. All safety instructions and regulations applicable to the escalator being cleaned must be strictly observed.

### **1.14 Procedure in case of emergency**

Lower machine, turn key switch to "0" and remove key.

## 2 Description

### 2.1 Technical data

Working width:		520 mm
Min step height:		185 mm
Max step height:		235 mm
Basic cleaning per step:		15 s (2x)
Maintenance cleaning per step:		27 s (2x)
Intensive cleaning per step:		39 s (2x)
Max air volume of suction:		162 m <sup>3</sup> / h
Low pressure:		300 mbar
Type of current / frequency:	A.C. current	50 Hz
Rated voltage:		110 V
Rated power input:		2300 W
Power output:	Brush motor	750 W
	Suction motor	1500 W
	Spindle drive	2x180 W
	Pump	40 W
Number of brushes:		18
Capacity of fresh-water tank:		20 l
Capacity of dirty-water tank:		20 l
Machine-dimensions:	Length	1094 mm
	Width	540 mm
	Height	1001 mm
Tare:		164 kg
Noise level:		78 ± 2 dB (A)



## 2.2 List of reference numbers

1	Brush	26	Pressure spindle
2	Guide rail	27	Fresh-water feeding
3	Cover f brush-replacement opening	28	Cover of dirty-water tank
4	Opening for brush replacement	29	Brake
5	Key switch	30	Trolley
6	RAISE machine	31	Fixing axle
7	Touch operation of brushes	32	Suction basin
8	Service hours counter	33	Stripping brush
9	STOP key	34	Seal strip
10	Automatic ON	35	Chain
11	LOWER machine	36	Spray nozzle
12	Emergency STOP button	37	Chain wheel
13	Suction machine OFF/ON	38	Suction machine
14	Mode switch	39	Collecting container
15	Touch operation for pump	40	Ball
16	Coupling for fresh-water-tube	41	Pressure spring
17	Fresh-water tank	42	Coupling ring
18	Hose bracket	43	Shaft
19	Side plate	44	Chain adjuster
20	Fresh-water tank cover	45	Filter
21	Dirty-water tank	46	Control panel
22	Spindle drive	47	Star handle
23	Traveling support	48	Left cover for suction sump
24	Safety support		
25	Glide rail		

## 2.3 Location of components

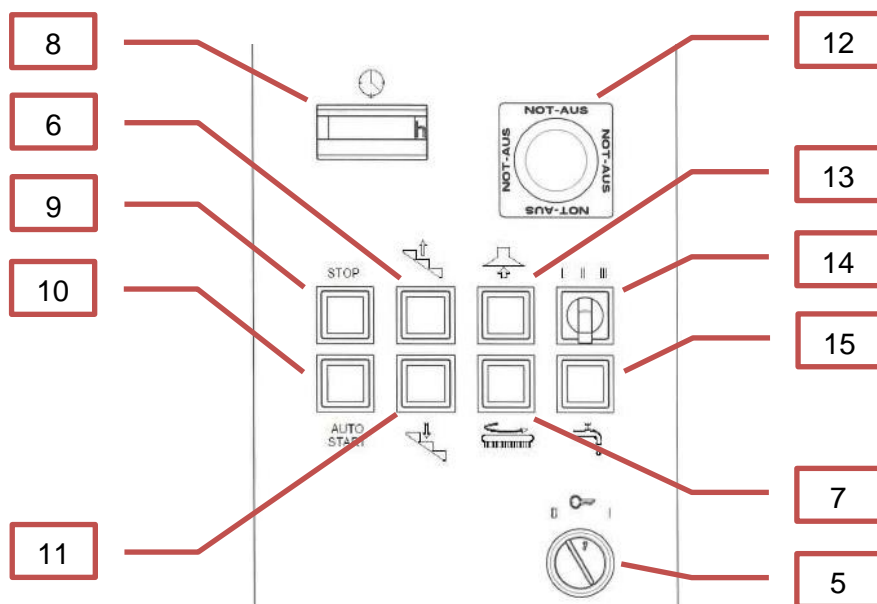

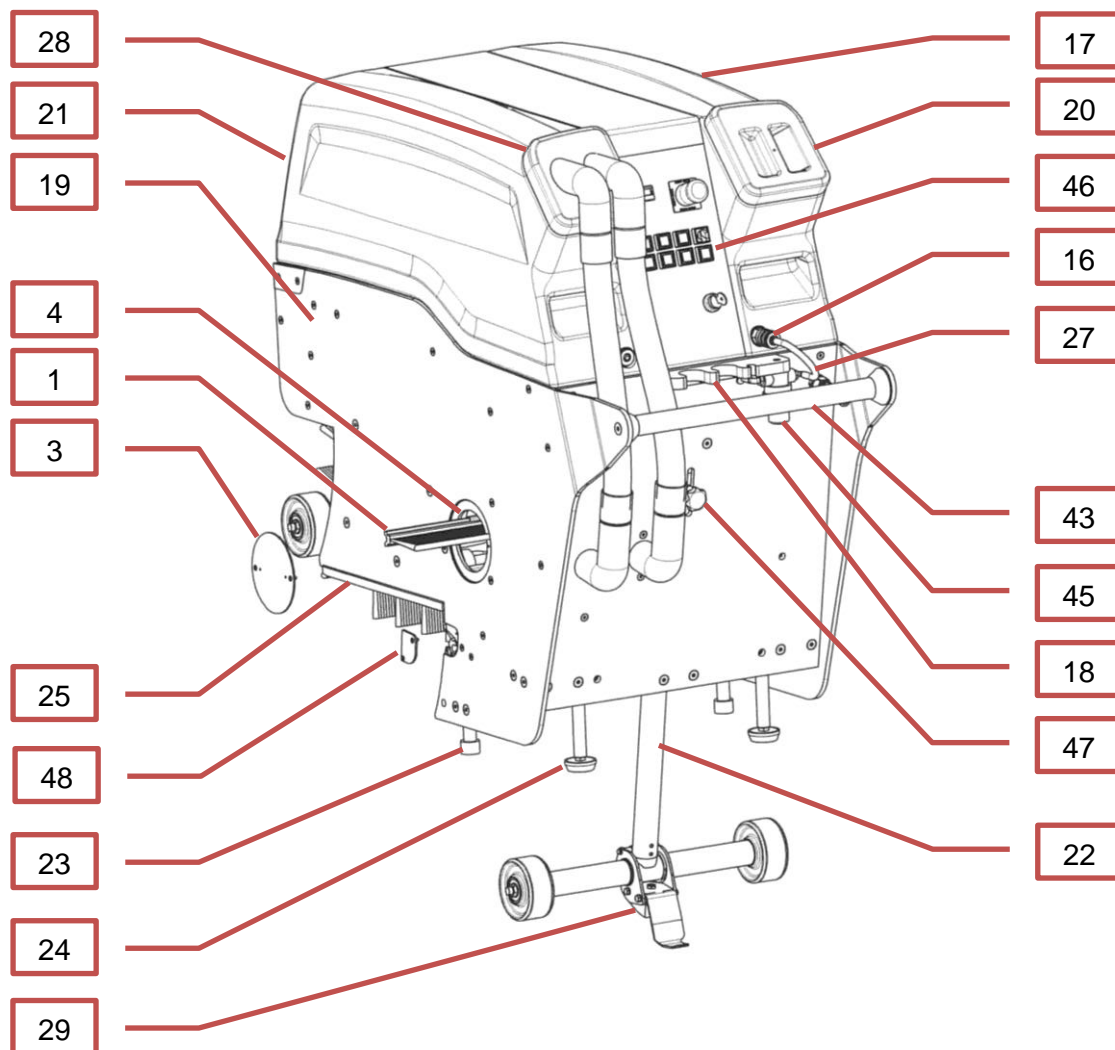

### 3 Operation

#### 3.1 Before start-up

All local safety regulations and instructions must be observed for each start-up.

The escalator must be inspected jointly with the party responsible for the escalator, who should also be informed of any discoloration or paint stains etc. caused by repair and renewal work..

#### 3.2 Assemble brushes

If brushes (1) have not yet been installed in the guide rail (2), the lid (3) on the opening for replacing brushes (4) in the left side wall should be opened (see Fig. 1: Brush assembly).



If possible, brushes of the same design (brush length, hardness etc.) should not be installed directly behind each other in order to avoid unbalance effects and to achieve an ideal cleaning result!

Make sure that one of the lids (3) is closed while putting the brushes into the machine.

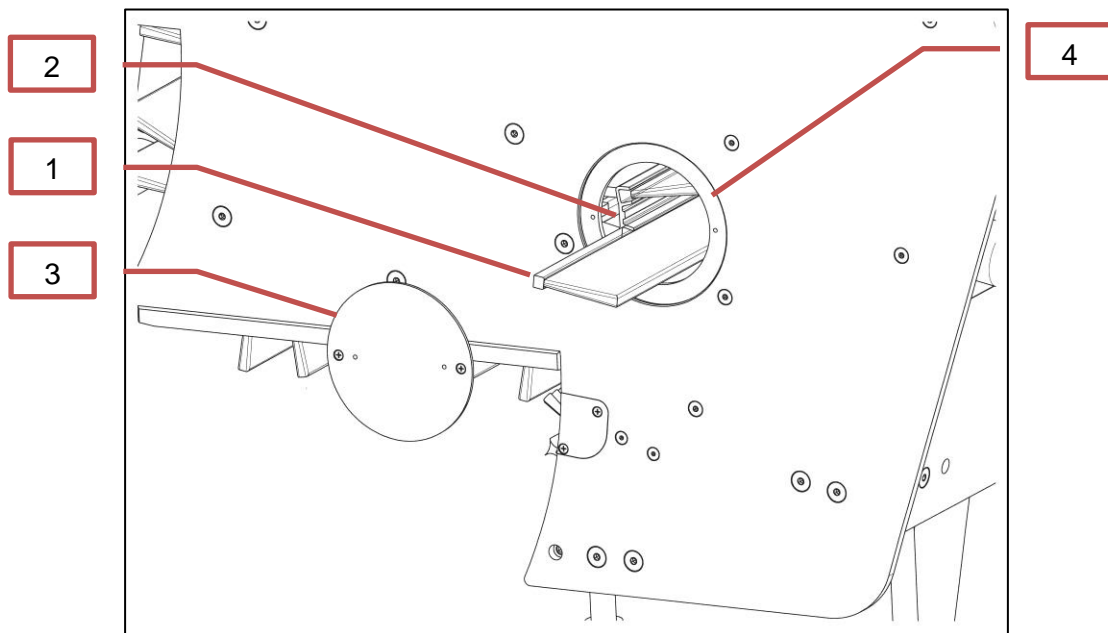

Figure 1 Brush assembly

The procedure below should be followed:

- Insert power plug.
- Set key switch (5) to "1".
- Raise machine [pushbutton (6) on operating console (46)].
- Move rail in the opening for replacing brushes (4) (pushbutton (7) Touch operation for bush).



Attention! When pushing the button the brushes start immediately to move.

- Set key switch (5) to "0".
- Shove in brush (1) until it hits against the right side wall.
- Set key switch (5) to "1".
- Move next rail completely in the opening for replacing brushes (4) (pushbutton (7) touch operation for brush).
- Set key switch (5) to "0".
- Repeat this procedure until all brushes have been inserted.
- Then screw on lid (3) once more.



Use only original columbus brushes: the size and shape of these have been tested and are adjusted to fit the escalator! A set of brushes consists of brushes with different brush lengths, bristles and bristle materials.

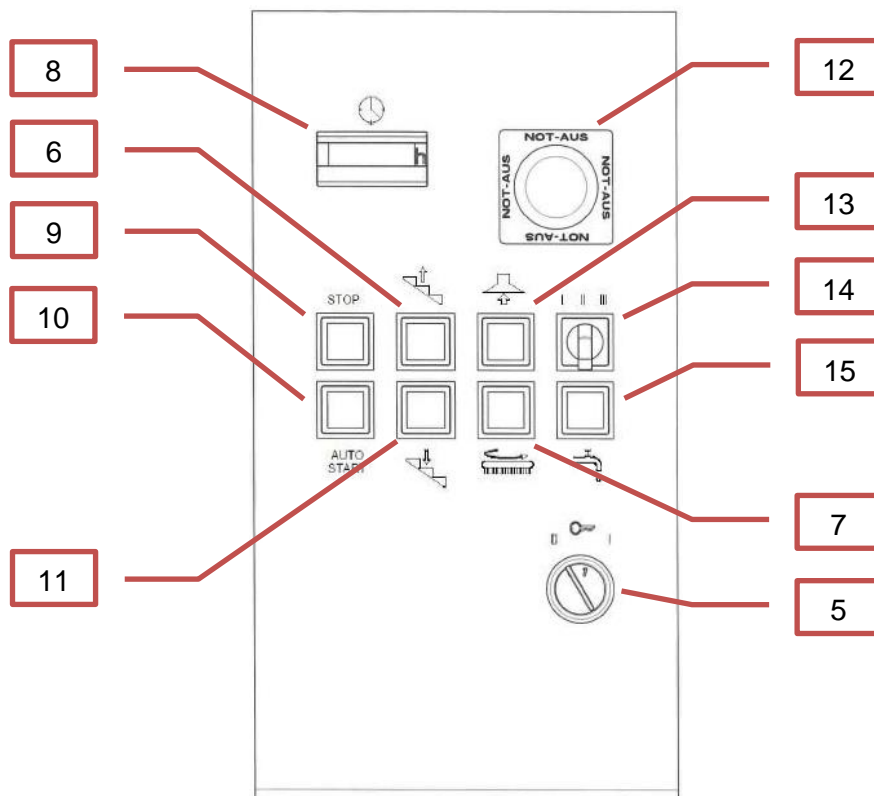

Figure 2 Control panel

### 3.3 Filling fresh water

- Unlock coupling (16) and separate from fresh-water tank (17).
- Clip in the coupling into the hose bracket (18).
- Draw fresh-water tank forward on the side plate (19) and withdraw from machine.
- Remove lid (20) and fill in a maximum of 20 litres of fresh water.
- Use the cleaning in the recommended mixing proportion (see operation instructions).



Each time the fresh-water tank is being filled, the dirty-water tank (21) should also be emptied. See Chapter 3.14 Emptying the dirty water tanks.

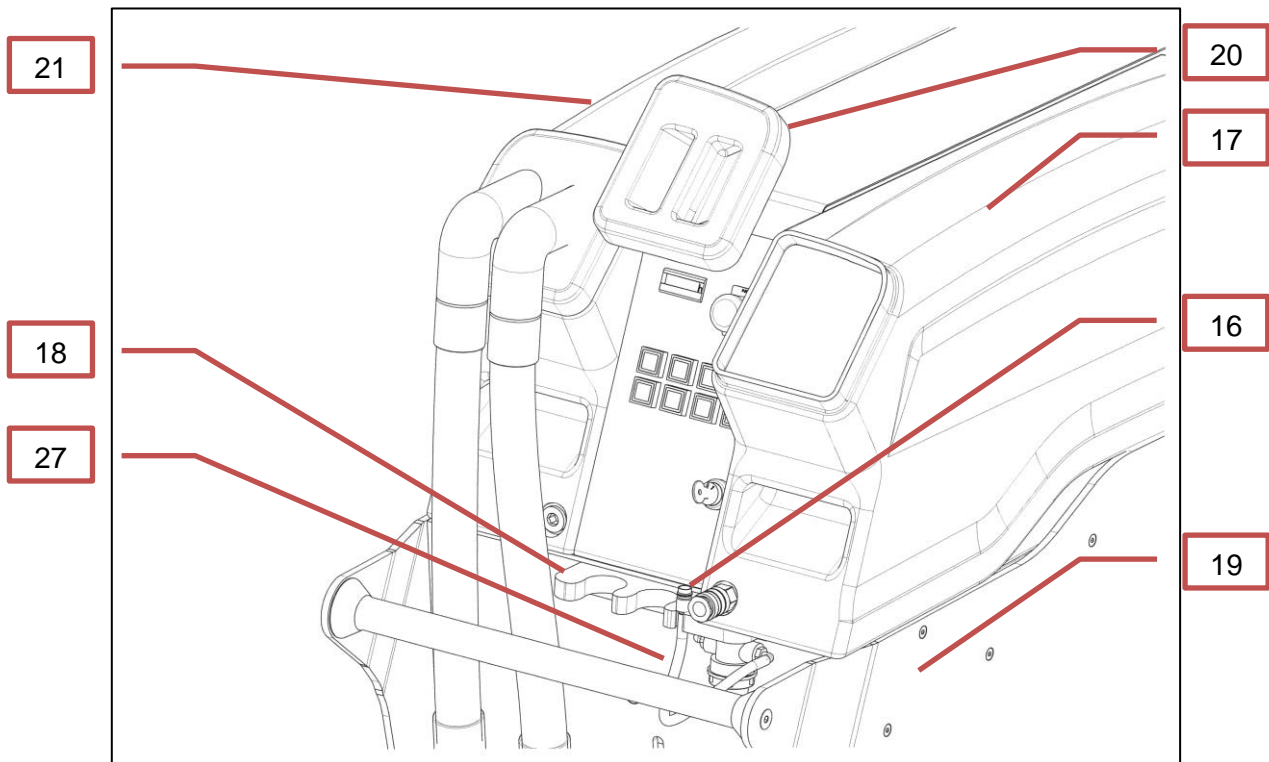

Figure 3 Fill up fresh water

### 3.4 Preparations on site

The cleaning date should be co-ordinated with the maintenance personnel (possibly process electrician) in charge of the escalator.

The safety manager should also be informed if necessary.



Have the escalator switched off by the relevant specialists and secured against being switched on by accident!

Remove escalator key!

The operator must plug in the mains cable for the machine, or a suitable socket must be shown to him.

The operator must furthermore obtain instruction on manual control of the escalator or else ensure that some person familiar with the workings of the escalator is available near by at all times.

### 3.5 Safety measures on site

All unauthorised persons must be prevented from approaching the entrances at both ends of the escalator by means of safety measures (e.g. red-and-white barrier chains).

The machine, the transport trolley and, when available, accessories trolley are to be placed in the cordoned-off level area at the bottom of the stairs to prevent any unauthorised use.

### 3.6 Preliminary work



All foreign bodies such as: cigarette packages, cans, etc. must always be removed before any work commences!



Any objects jammed in the machine, such as small stones, bits of glass, etc. are a significant impediment to achieving a good result. Care must therefore be taken that all such objects are removed in advance. The handheld cleaning equipment is ideal for this purpose!

Remove any dirt from the grooves in the steps with the 4 cm hand rake before vacuuming, brushing or sweeping clean.



Handheld cleaning equipment should not be left lying on the escalator, otherwise there is danger of it being drawn into the machine!

### 3.7 Working instructions



The detergent applied to the escalator surface will lead to danger of slipping!

Shoes with non-slip soles must therefore always be worn during work on the stairs!

Scratching or erosion on the escalator steps caused by wear, corrosion or material faults can not be repaired.

### 3.8 Positioning the machine on escalator

The machine with extended lifting spindles (18) should then be shoved into the escalator and moved by authorised escalator operators to the first completely extended step (Fig. 4: Fixing the machine).

The escalator is then stopped completely.



Ensure that the escalator is switched off by the relevant personnel and secured against accidental starting !

Remove escalator keys!

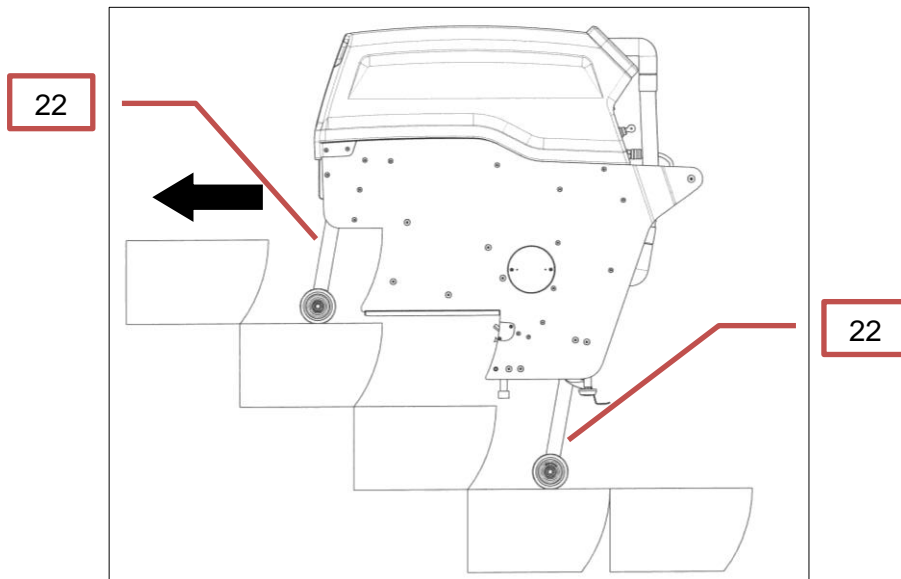

Figure 4 Fixing the machine

### 3.9 Setting step height



The machine is in danger of falling if the travelling supports (23) and safety supports (24) are not adjusted properly to the step height of the escalator to be cleaned.

- Move machine to the first completely extended step.
- Fix the machine in the middle of the escalator.
- Pull the star handle (47) down. Then lower the machine. The machine has to stand on the rear legs now. So the gliding rails (25) do not touch the escalator completely.
- Open the attachment screw and check if the travelling support (23) and the safety support (24) touch the escalator.
- Move the star handle (47) to a higher position (move it a bit more to the top than the highest distance between the escalator and the gliding rail (25)).
- Lift the machine (6) and lower (11) it. Now the whole gliding rail (25) have to touch the escalator. If not then please move the star handle (47) more to the top and repeat the process.
- Tighten the attachment screws again and make sure that the travelling support (23) and the safety support (24) touch the escalator.



Make sure that the machine is resting uniformly on the two travelling strips and all four supports and that the wheels are approx.. 3-4 mm distant from the step!

If this is not the case, the adjustment procedure must be repeated!



Incorrectly adjusted travelling supports (23) will mean that the operator will have to use more force! In addition the travelling supports (23) brake earlier.

- Start the cleaning operation.



It will be possible to start the cleaning process only when the running gear has been driven to the point where the limit switch is activated at the lifting spindles (22) and the green light in the AUTO-START-button (9) blinks!

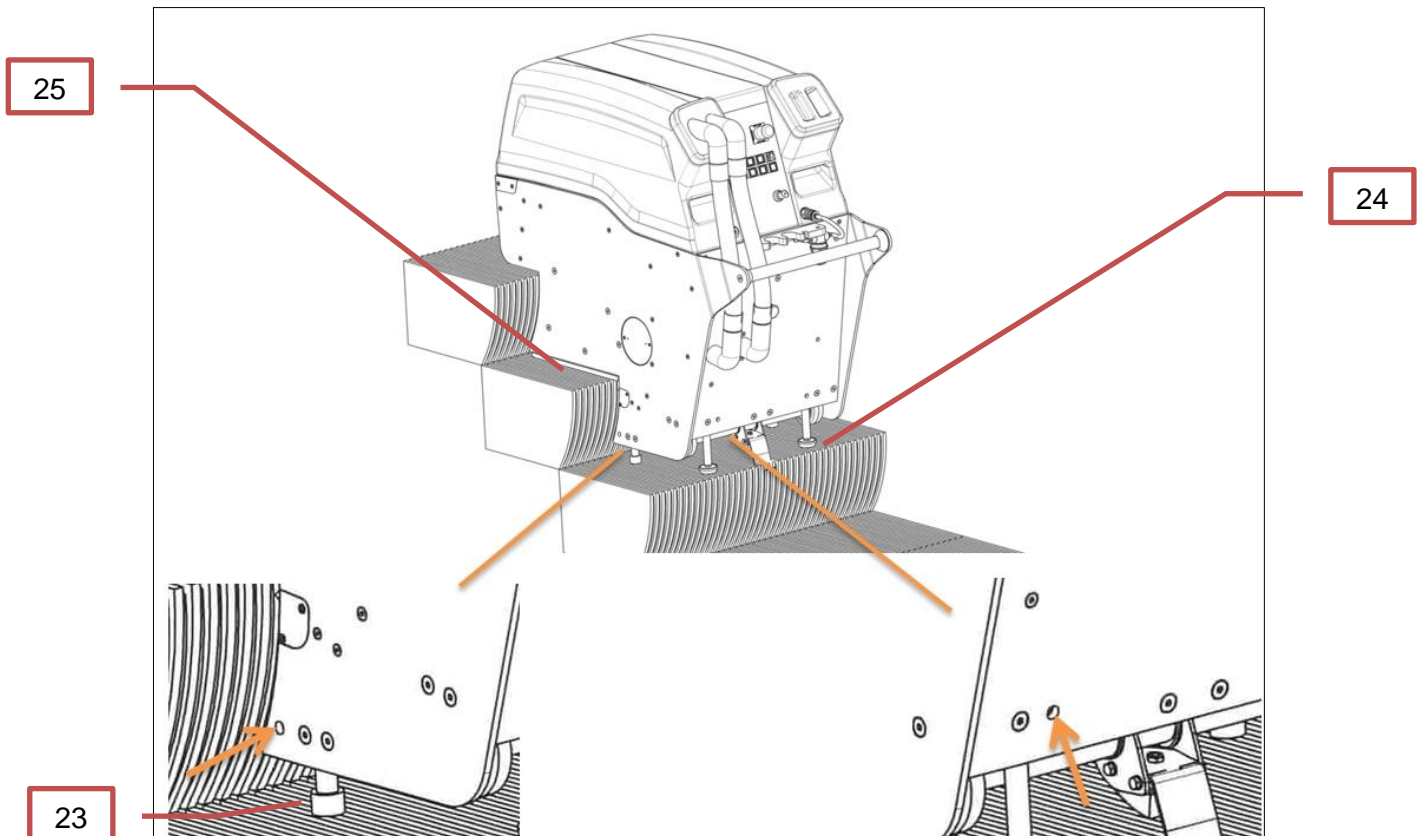

Figure 5 Setting step height

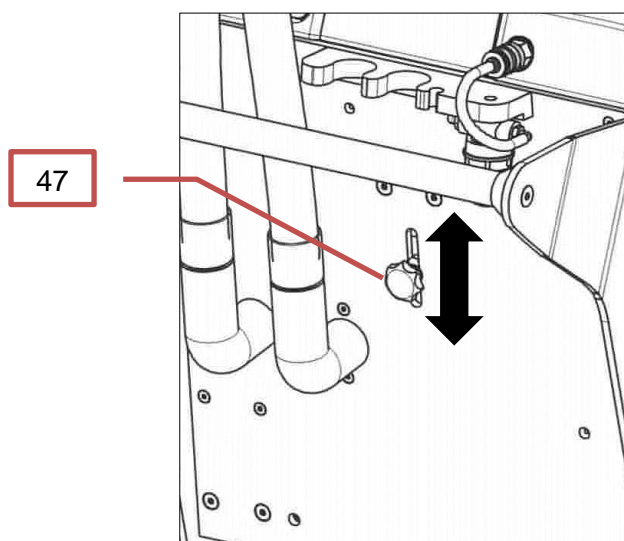

Figure 6 Highadjustment help



### 3.10 Select cleaning programmes

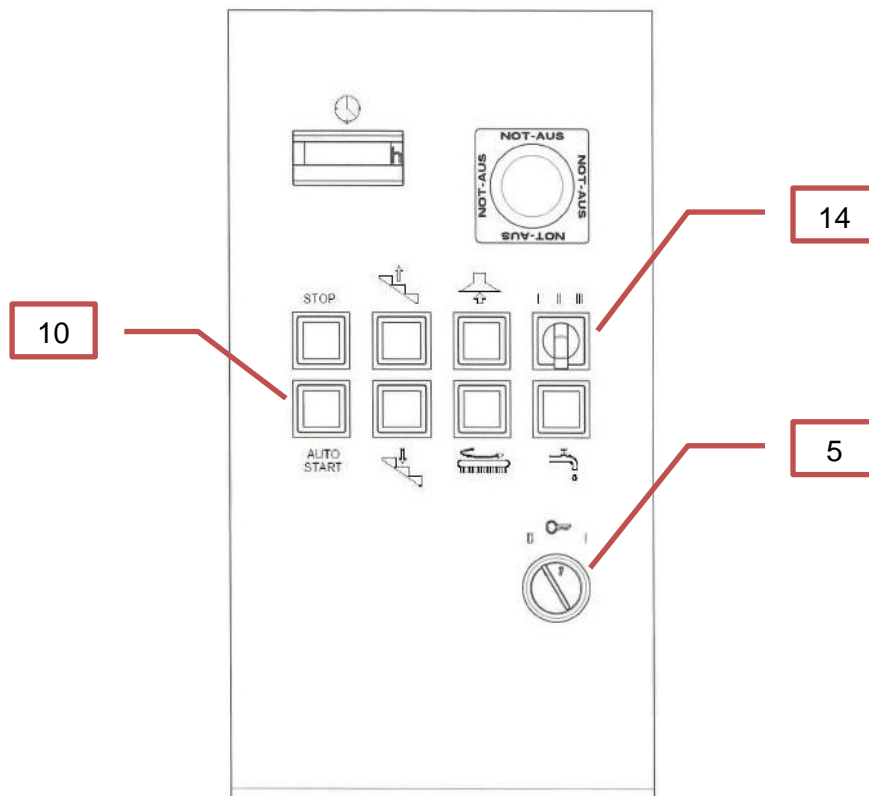

Figure 7 Control panel

The machine is provided with 3 cleaning programmes, which have been tested and optimised by columbus.. An ideal cleaning performance is achieved with a minimum use of water.

#### 3.10.1 Programm 1: Quick cleaning cycle

(Duration of the cleaning cycle 15 seconds)

- Put Key switch (5) on „1“.
- Press Automatic ON (10).

#### 3.10.2 Programm 2: Maintenance cleaning cycle

(Duration of the cleaning cycle 27 seconds)

- Put Key switch (5) on „1“.
- Choose program „2“ with the mode switch (14).
- Press Automatic ON (10).
- Switch from program 2 to program 1 during the cleaning cycle: Same process as program 2.
- Switch from program 1 to program 2 during the cleaning cycle: Same process as program 1.

#### 3.10.3 Programm 3: Intensive cleaning cycle

(Duration of the cleaning cycle 39 seconds)

- Put Key switch (5) on „1“.

- Choose program „3“ with the mode switch (14).
- Press Automatic ON (10).
- Switch from program 3 to program 2 during the cleaning cycle: Same process as program 3.
- Switch from program 2 to program 3 during the cleaning cycle: Same process as program 2.

### 3.11 Cleaning the escalator

In order to achieve an ideal moisture content on the brushes, the first step should be cleaned twice at the beginning of the cleaning operation. After the machine - lying on the left side of the escalator - is shoved into the escalator step until the wheels stop until the seal strip (34) is arrested (Fig. 9: Positioning the machine).

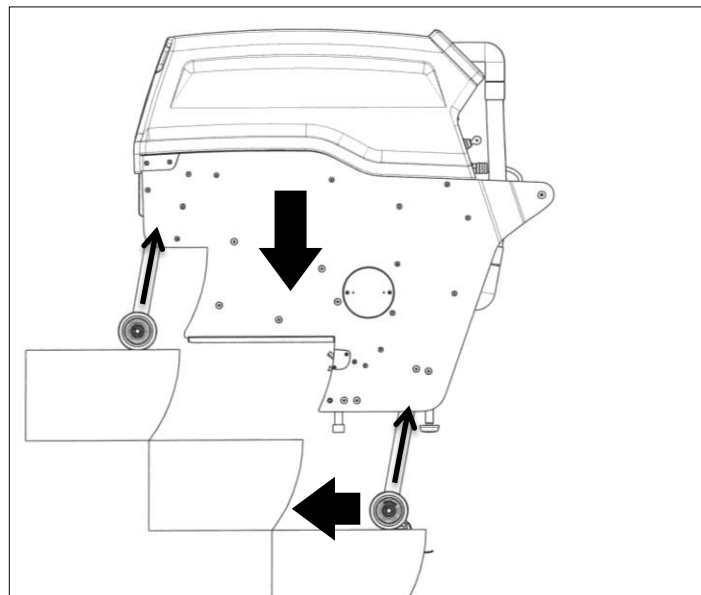

Figure 8 Lowering the machine

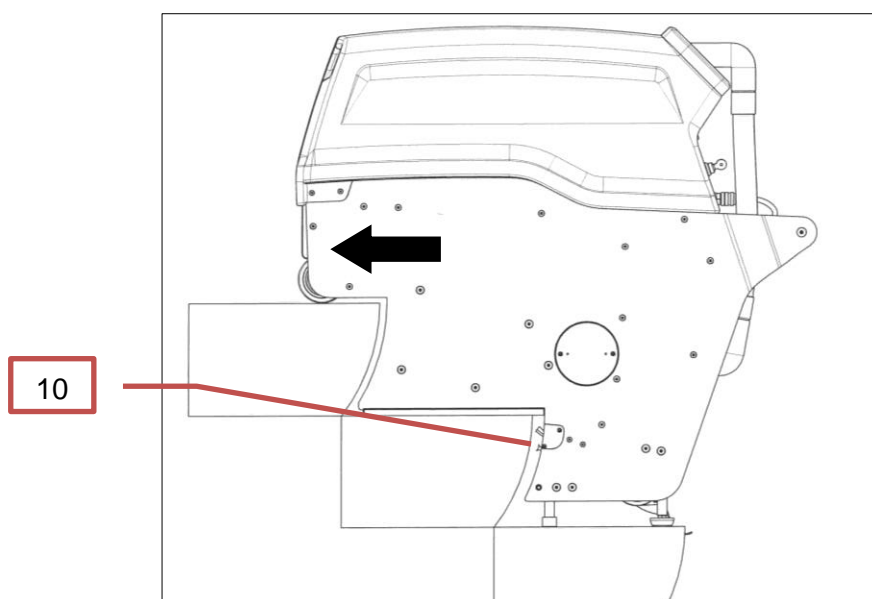

Figure 9 Positioning the machine

The pre-selected programme can now be started. When the cleaning cycle has been completed, the machine is raised (Fig. 9: Raising the machine).



When raising the machine, the operator must ensure that the glide rails do not hang on the inside walls of the escalator.

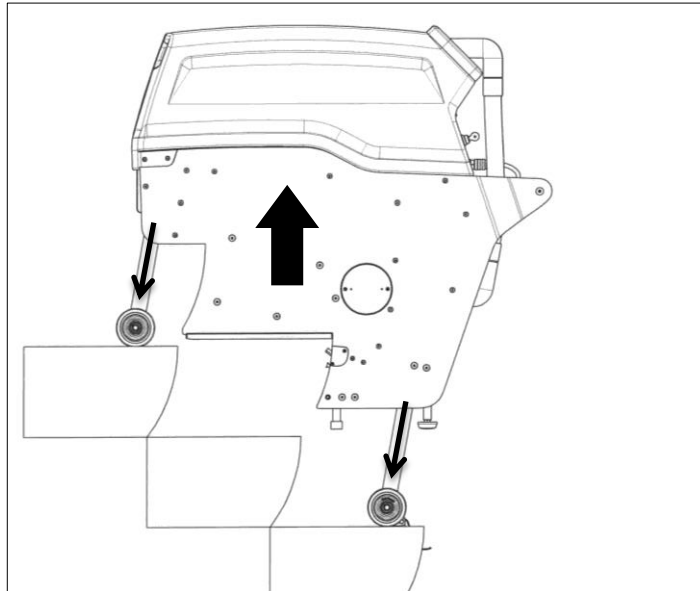

Figure 10 Raising the machine

The machine is then shoved forward again until the wheels stop on the next highest step (Fig. 4: Fixing the machine), and then lowered again. The machine can now be shoved on the glide rails into the new working position (Fig. 9: Positioning the machine).

Repetition of the procedure described above will allow the escalator to be cleaned from the bottom to the top completely-extended step.



Always ensure that the power cable is disconnected and wound up before the escalator is started again to avoid accidents!

The switched-off and lowered machine is then driven downwards with the escalator to the position of the last extended step.

After the cable has been connected once more, the procedure described above can be started anew and the escalator cleaned again up to the top completely extended step. After the machine has been run from the lower to the highest completely extended step, one side of the escalator will have been cleaned.

The machine must now be shifted from the left to the right (Fig. 11: Shifting the machine). Therefore lift the machine about 3 to 5 cm and push it on the gliding rails to the other side.



Do not push the machine on the gliding rails! They can be ruined.

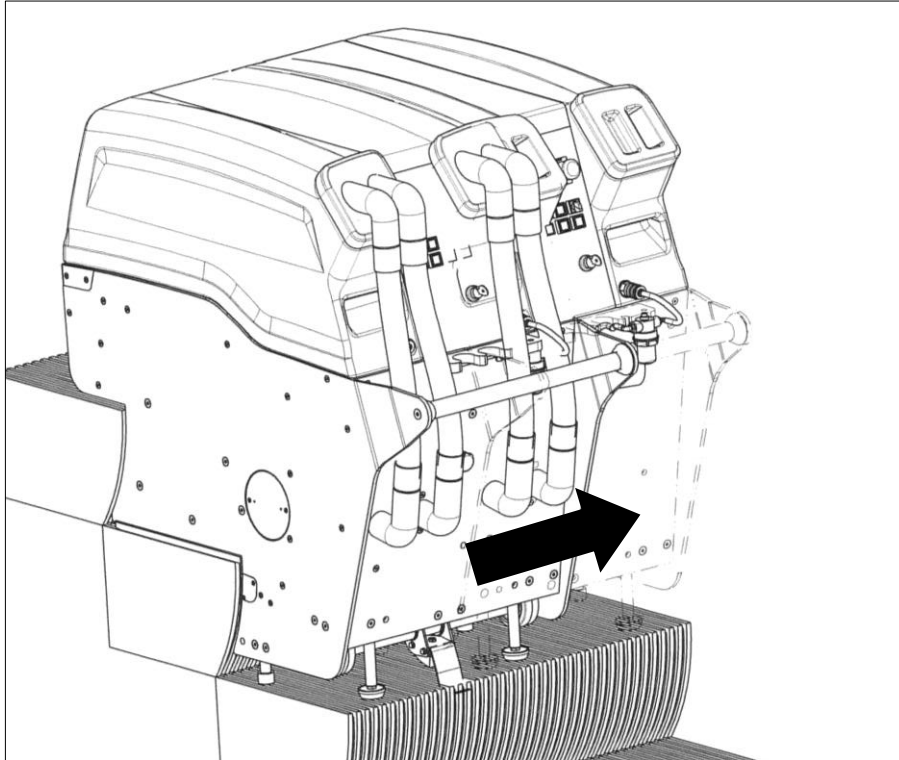

Figure 11 Shifting machine

The cleaning process can then be started for the right side and take place as described above.

### 3.12 Subsequent cleaning

Manual cleaning equipment has been developed by columbus by means of comprehensive practical tests.

With this equipment, any subsequent cleaning that may become necessary, such as major soiling on the edges and the joining areas between two steps, can be carried out easily.



The manual cleaning equipment manufactured by columbus is particularly suitable for minor subsequent cleaning.

### 3.13 Refilling with fresh water

The operator must carry out regular checks at the transparent feeder tube for fresh water (27) to ensure that the machine is receiving a supply of detergent solution. If bubbles appear in the tube or if no liquid can be seen, the fresh-water tank is empty and must be refilled.

Let the machine stand in the lowered position on the escalator and fill fresh water along with cleaning agent according to instructions in Chapter 3.3.



When the fresh-water tank is being filled it is essential that the dirty-water tank is emptied.

### 3.14 Emptying the dirty-water tanks

(see Fig. 12 Remove dirty water tank and Fig. 13: Insert dirty water tank)

- Set key switch (5) to "0" position.
- Draw the dirty-water tank (21) forward and set down onto the side plate (19).
- Put in the suction tubes into the hose bracket (18)
- Remove tank lid (28) and put it to the side.
- Grip tank on the carrying-troughs and dispose of dirty water according to the relevant environment regulations.



All valid regulations regarding waste water must be strictly observed when the dirty water is being dumped!

- Place dirty-water tank (21) onto the side plate (19) and insertion area.
- Replace tank cover (28).
- Adapt the suction tubes (take care of the correct fitting; the tubes have to be adapted so that they do not cross each other!)
- Shove in tank (21) and check secure mounting.
- Set key switch (5) to position "1".
- Start suction with START/STOP key (9).
- Check fitting of tank cover (28)!
- Switch off suction with START/STOP key (9).
- The work can now be continued.

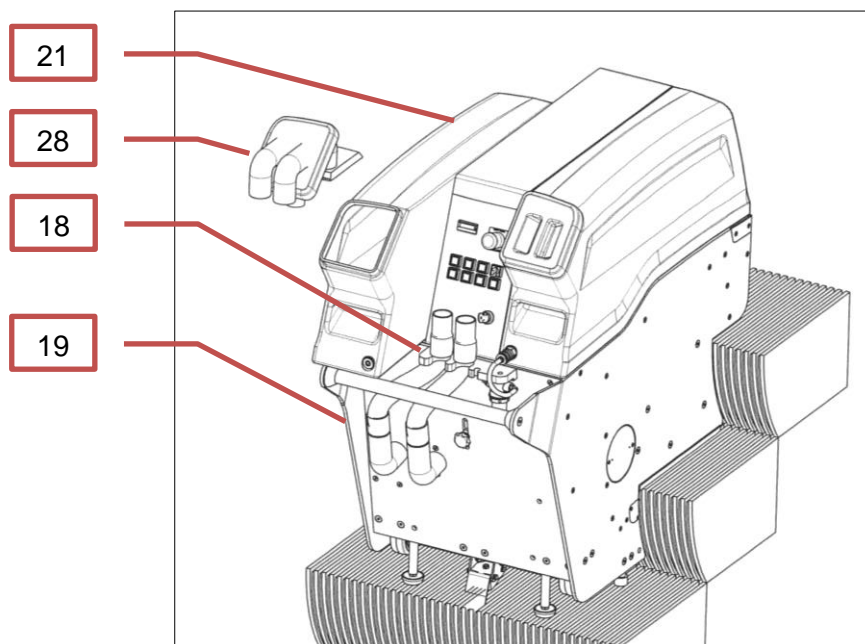

Figure 12 Remove dirty water tank

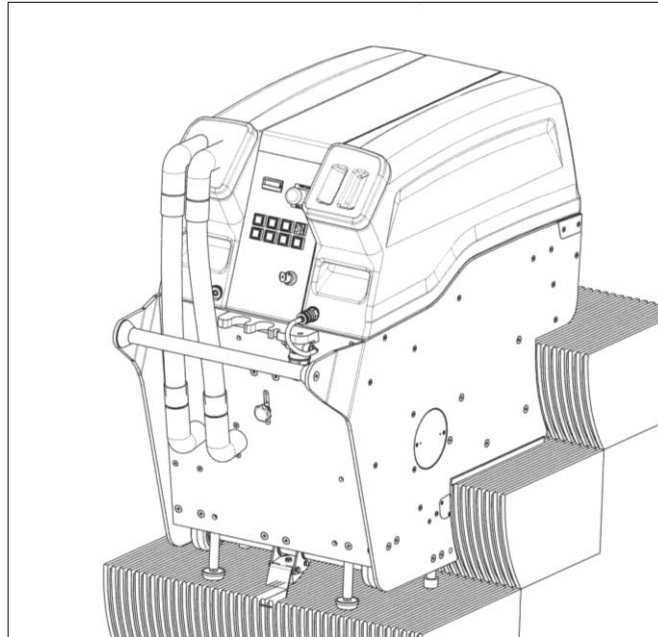

Figure 13 Insert dirty water tank

### 3.15 Ending the cleaning process

- Move machine as described in Chapter 3.11 with the escalator to the lowest completely extended step.
- The machine is then raised over the lifting spindle drive (22).
- If the escalator is going downwards, leave the escalator at the lower end, while making sure that:



When the machine is driving over the rim comb the rear axle along with the brake (29) must always be raised in order to prevent the machine catching on the escalator's rim combs



While removing the step 100 off the escalator put a piece of carton under the brake so it cannot hook in the comb of the escalator.

Take out the machine with transport trolley (see Chapter 3.16 Use of the transport trolley) and bring to place of storage.

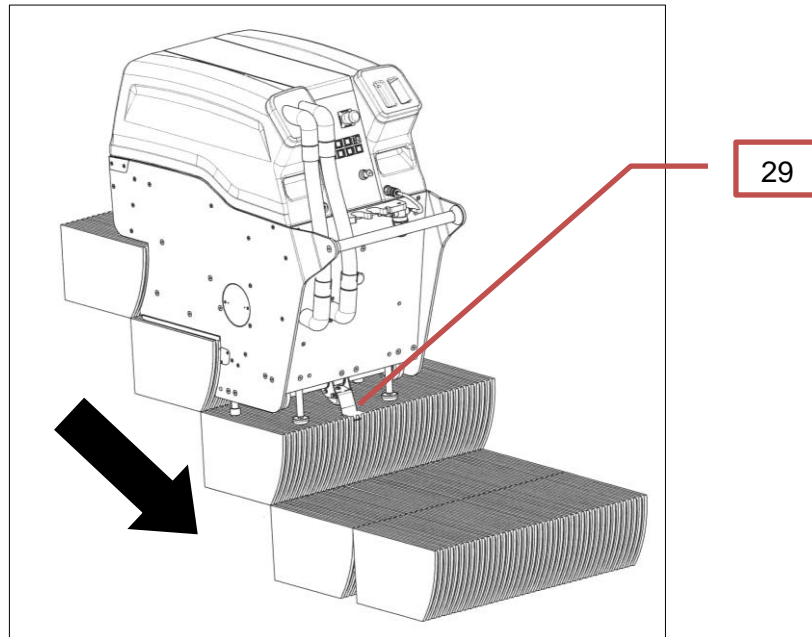

Figure 14 Removal of machine from escalator

### 3.16 Use of transport trolley

#### 3.16.1 Preparation for transport

For transport, the machine is removed from the transport trolley with the shaft in front after the fixing axle (31) has been removed and driven into the shaft (see Fig. 15: Moving into transport position).

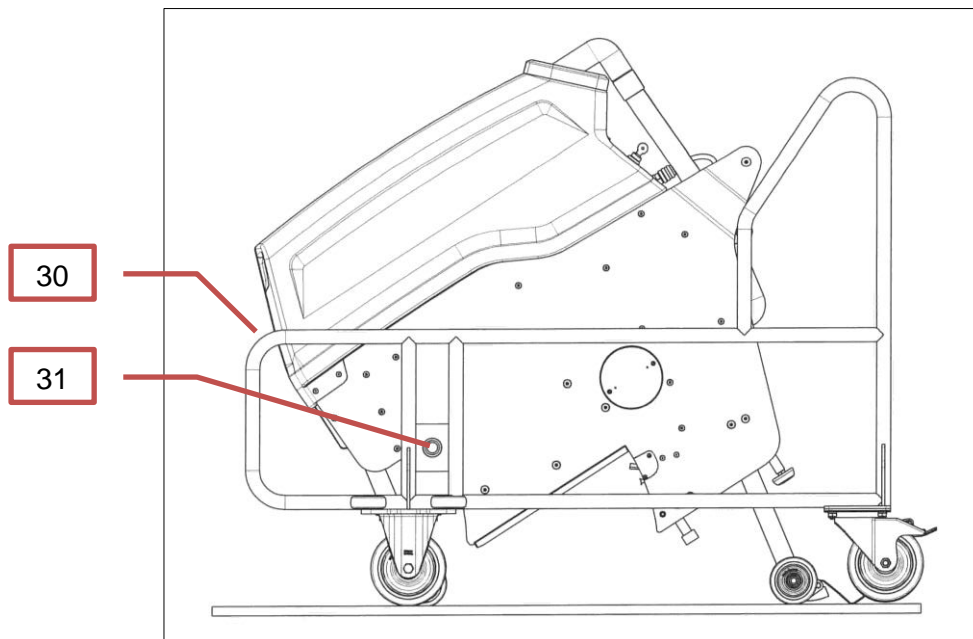

Figure 15 Moving into transport position



Before the travelling mechanism is driven from the stairs, the rollers on the transport trolley must always be secured with the brakes!

After the fixing axle (31) has been inserted and secured, the travelling mechanism can be drawn in and the machine thus placed on the transport trolley.



The fixing axle (31) must be secured against slipping out by means of the supplied permanent cotter pin !

The guide rollers of the transport trolleys allow the machine to be manoeuvred easily (see Fig. 16: Machine in transport position).

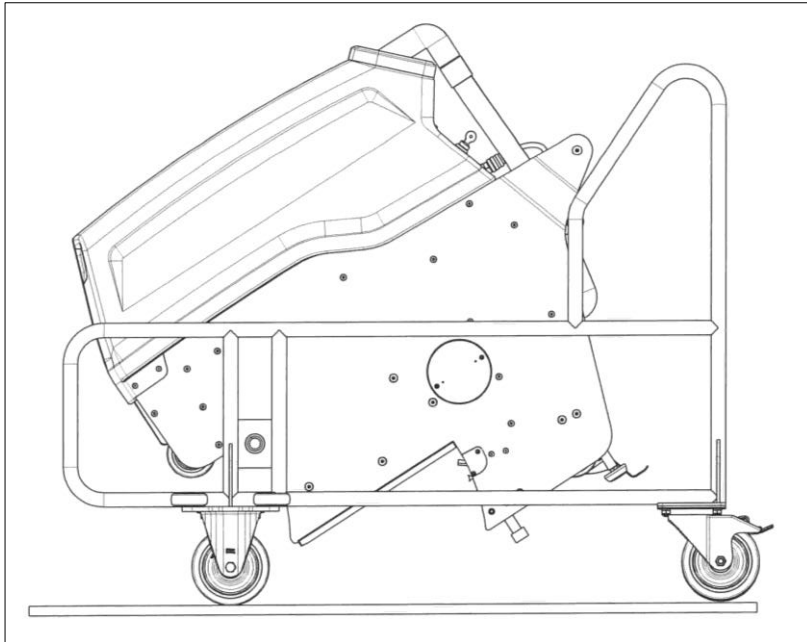

*Figure 16 Machine in transport position*

### **3.16.2 Use of transport trolley for maintenance**

In preparation for maintenance, the machine is removed from the transport trolley with the shaft in front, after the fixing axle (31) has been withdrawn, and driven into the shaft (see Fig. 17: Moving into maintenance position).

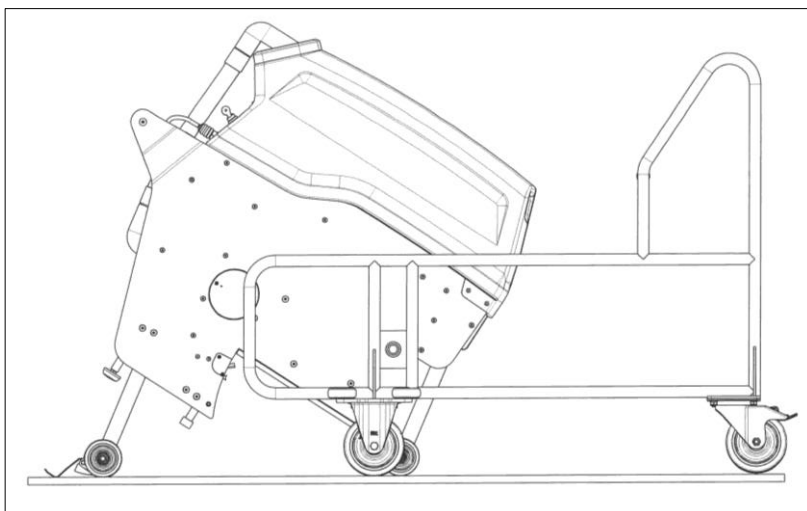

*Figure 17 Moving into maintenance position*





Before the travelling gear is drawn in, the roller of the transport trolley must always be secured with the brakes!

After the fixing axle (31) has been inserted and secured again, the travelling gear can be drawn in to about a third its length and the machine then swung into the maintenance position on the trolley.



The fixing axle (31) must be secured against slipping out by means of the supplied permanent cotter pin!



Before turning the machine remove both tanks (17; 21) and their covers (20; 28). Otherwise they can be damaged!

In this way maintenance and cleaning work can be carried out easily and quickly (see Fig. 18: Machine in maintenance position).

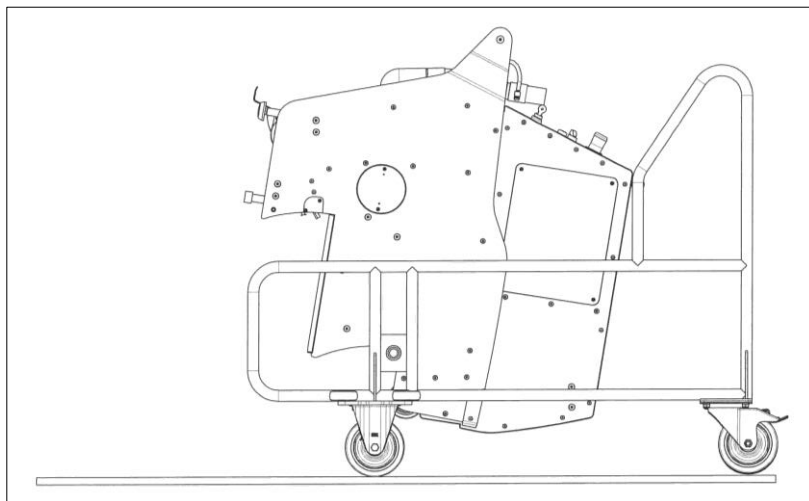

Figure 18 Machine in maintenance position

## 4 Maintenance / Care

### 4.1 Safety measures during cleaning and maintenance of the machine

- Before any maintenance or cleaning work is carried out, the machine must be separated from the mains with the main switch being set to "0" and the mains plug disconnected. This will prevent accidents caused by electrical voltage or moving parts.
- During cleaning or maintenance work on the machine, when parts are being replaced or new equipment fitted for a new function, care must be taken that the machine can not accidentally start, roll or turn over and that no parts can fall down or flap closed.

If the operator has any questions or doubts regarding safety, he must request advice from the manufacturer or the relevant sales agent before starting the machine.

### 4.2 Daily care

- Examine the power cable for any damage.
- Always empty the dirty-water tank (21) following use and rinse thoroughly with water
- Inspect brushes (1) and clean.
- Rinse out suction basin (32).
- Clean stripping brush (33).

### 4.3 Weekly care

- Clean and lightly lubricate the extended lifting spindles (22).
- Check suction tubes for leaks.
- Check seal strips (34) and renew if necessary (Fig. 19: Seal strip).

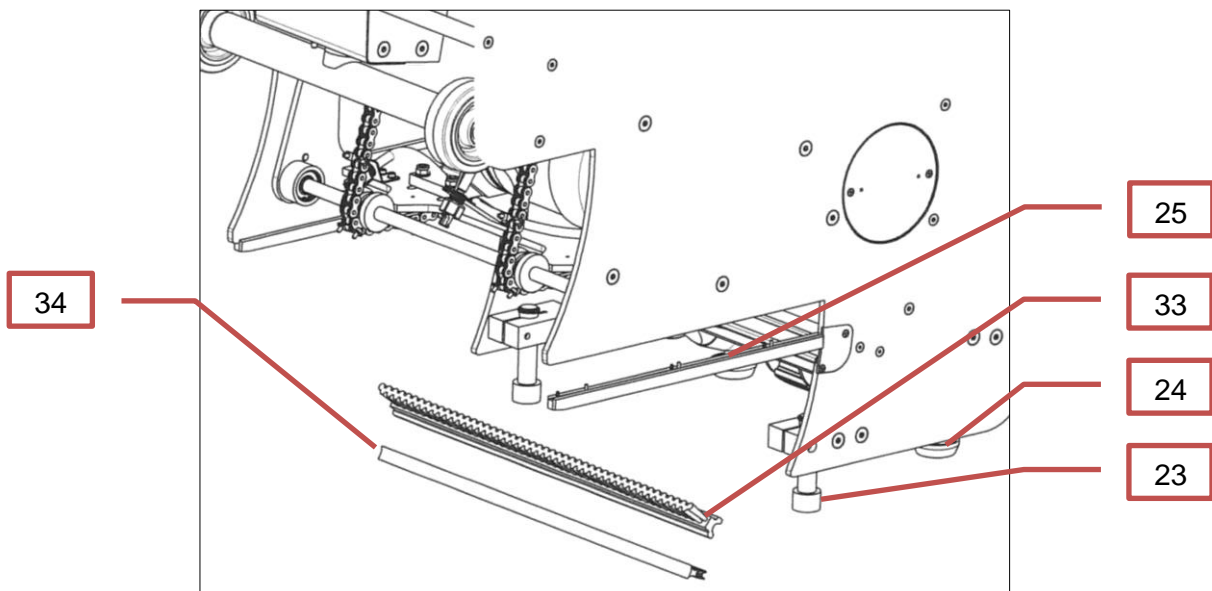

Figure 19 Seal strip

### 4.4 Maintenance after 30 service hours



Maintenance work may be carried out by trained personnel only.

- Remove suction basin (32) and stripping brush (33) and rinse (Fig. 18: Seal strip)
- Check chains (35) for correct tension and, if necessary, tighten with chain adjuster 44) (see Chapter 4.6.1 Tightening the chain and Fig. 20: Chain drive /Spraying nozzle).
- Clean chains (35) and treat with a chain spray.
- Check spray nozzles (36) and clean if necessary.
- Check glide rails (25) on the right and the left. Replace if showing signs of wear (Fig. 19: Seal strip).
- Check sliding elements of the step adjustment device (23 and 24). Replace in case of wear.
- Check seal strip (34) and renew if necessary (Fig. 18: Seal strip).

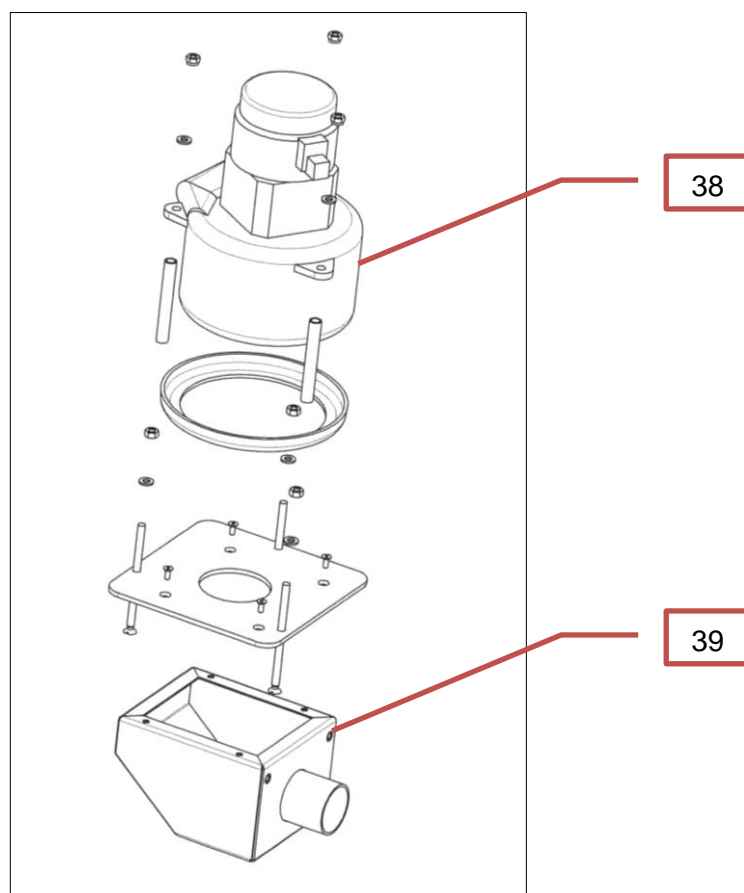

Figure 20 Collecting container

#### 4.5 Maintenance after 100 service hours



Maintenance work may be carried out by trained personnel only.

- Maintenance work in this case should be carried out as after 30 service hours, but here the chains (35) and chain wheels (37) must be checked for wear and replaced if required (see Fig. 21: Chain drive / spray nozzle).

- The brushes (1) must be dismantled and inspected (Fig. 1: Brush assembly). New brushes must be fitted when necessary.
- Clean collecting container (39) under the suction device (38).
- Check all electrical components.

## 4.6 Animal maintenance

An electrically driven machine must be examined every year in accordance with VDE 702 or some comparable international standards.



This examination must be carried out by a service technician trained Columbus.

### 4.6.1 Tightening the chain

(see Fig. 21: Chain drive / spray nozzles)

The chains must be tightened so that the centre of each chain can be raised by hand between the chain wheels by approx. 3 mm ("A") or pressed together by 4 - 5 mm ("B").

The chain can be tensioned by adjusting the pressure spindle (26) in the direction of the arrow.



The suspension chains on the left and right ("A") must always have the same tension!

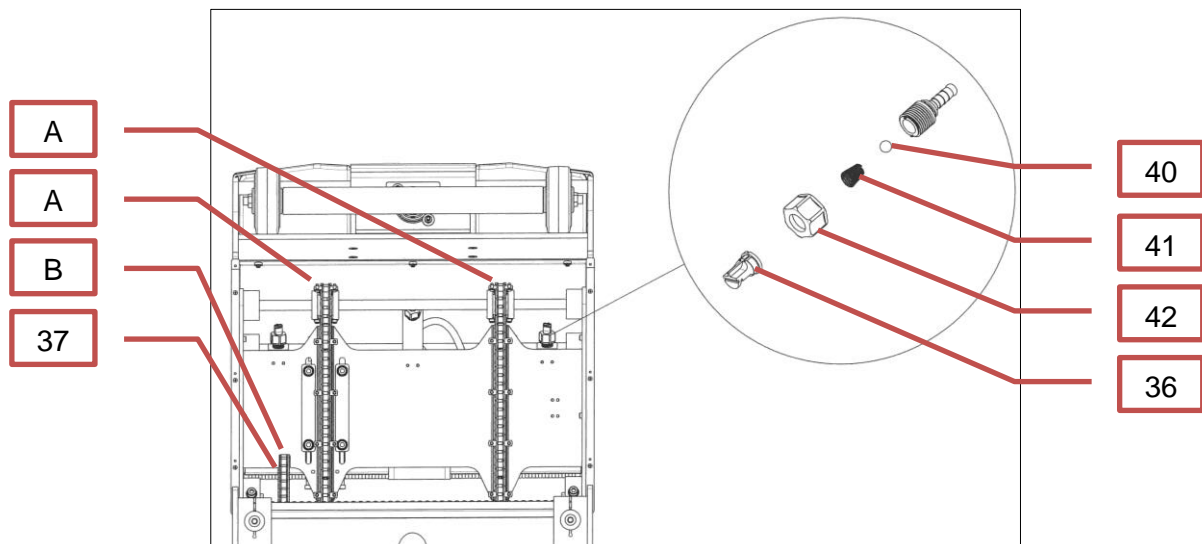

Figure 21 Chain drive / spray nozzles

The wearing limit of a chain has been reached when the distance "s" between the 1<sup>st</sup> and 12<sup>th</sup> roller exceeds 135.0 mm; see Fig. 22: Wear measurement chain drive.

With a brand new chain this dimension "s" should measure 131.4 mm.

These values are valid for all 3 chains.

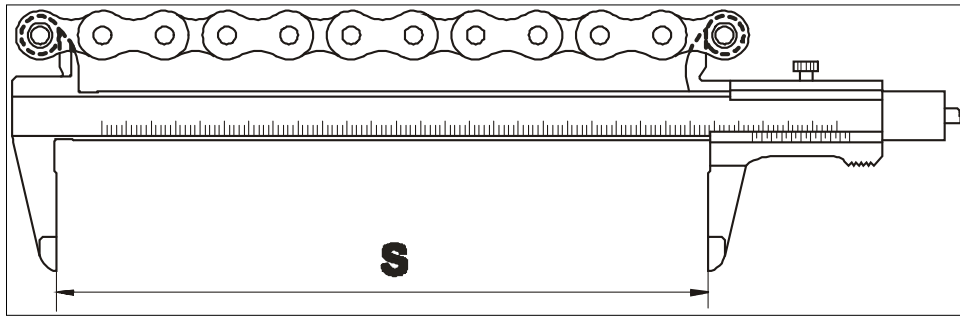

Figure 22 Wear measurement chain drive

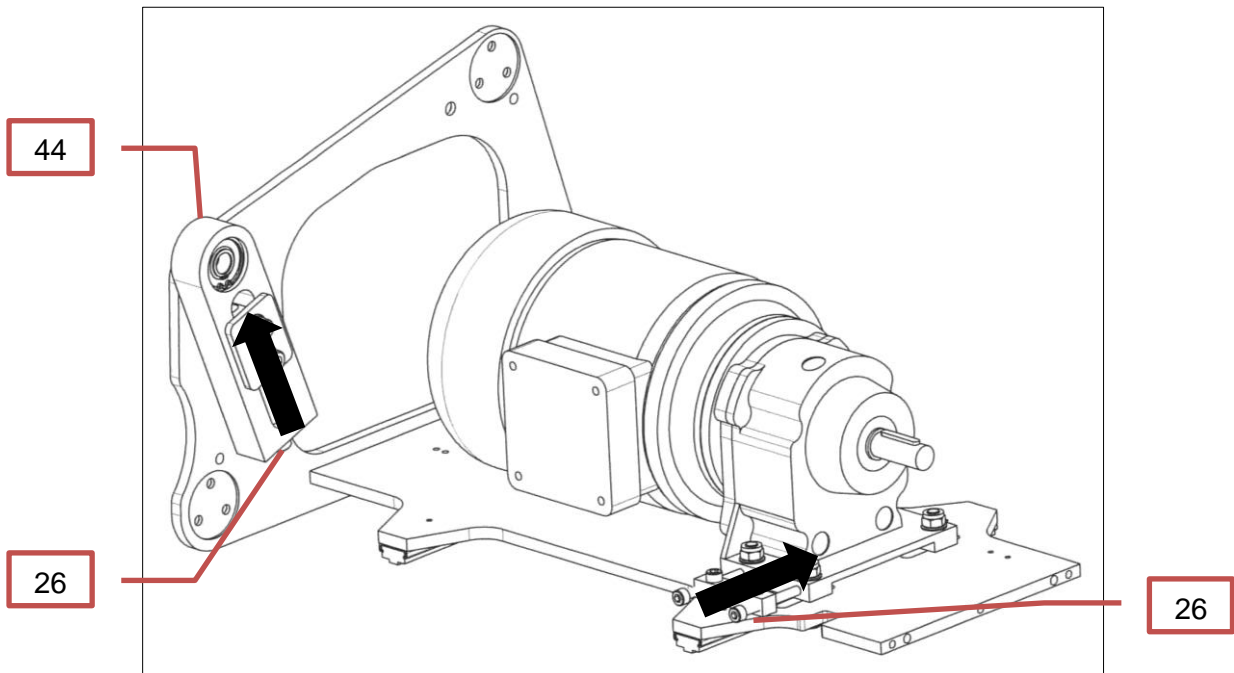

Figure 23 Tightening the chains

#### 4.6.2 Cleaning and replacing fresh water nozzles

(see Fig. 21: Chain drive / spray nozzle)

- Screw off coupling ring (16).
- Remove pressure spring (41), spray nozzle (36) and ball (40).
- Clean spray nozzle, using only instruments without sharp edges.
- Re-assemble fresh-water nozzle as shown in illustration, while making sure:



The spray nozzles must be aligned in their mounting according to the turning safety device! The coupling ring (42) should only be twisted on manually!

**4.7 Troubleshooting and remedy**

<b>Fault</b>	<b>Cause</b>	<b>Remedy</b>
Machine cannot be started with AUTOSTART	Lifting spindles (22) are not in end position	Press LOWER key (11) once again
Machine cleans poorly	Spray nozzle (36) is blocked	Clean spray nozzle (36)
	Brushes (1) are soiled	Clean brushes (1)
	Brushes (1) are worn	Replace brushes (1)
Detergent return to the machine is too low	Seal strip (34) is defect	Replace seal strip (34)
	Stripping brush (33) is dirty	Open the e.g. the left cover for the suction sump (48) and clean stripping brush (33)
Dirt streaks are visible on front face	Stripping brush (33) is dirty	Open the e.g. the left cover for the suction sump (48) and clean stripping brush (33)
	Stripping brush (33) is worn	Open the e.g. the left cover for the suction sump (48) and clean stripping brush (33)
Water residues on escalator	Cover (28) of dirty-water tank (21) does not close tight	Attach cover (28) anew
	Cover (28) of dirty-water tank (21) does not close tight	Replace tank cover



If the fault in the machine cannot be remedied according to the procedures described in the table above, the customer service of columbus should be notified and the necessary repair work carried out by its staff.

## 5 Declaration of Conformity

in accordance with the EC Directive on Machines 2006/42/EC



G. Staehle GmbH u. Co. KG  
columbus Reinigungsmaschinen  
Mercedesstraße 15  
D-70372 Stuttgart

hereby declares that the following product conforms to the regulations of the above mentioned directive –  
as well as any modifications valid at the time the declaration was made.

Product: **Escalator Cleaning Machine**

Types: **step 110**

The following related standards apply:

DIN EN ISO 12100  
DIN EN 60204-1  
DIN EN 60335-1  
DIN EN 55014-1  
DIN EN 61000-3  
DIN EN ISO 13857

The following further EU Directive apply:

EMC Directive	2014/30/EU
Low Voltage directive	2014/35/EU

Stuttgart, 15.10.2018

Dipl. Ing.(BA) Erich Stockmann, Head of Design and Development

Authorised Documentation Representative: Dr. M. Baumgärtel











**G. Staehle GmbH u. Co. KG**  
**columbus Reinigungsmaschinen**  
Mercedesstr.15  
D - 70372 STUTTGART  
Telefon +49(0)711 / 9544-950  
Telefax +49(0)711 / 9544-941

[info@columbus-clean.com](mailto:info@columbus-clean.com)  
[www.columbus-clean.com](http://www.columbus-clean.com)

**columbus**