

STACKER

NOZZLE

The stacker is used to connect exhaust extractors to vertical/upward turned exhaust pipes and to exhaust pipes that are centrally positioned under a vehicle.

The stacker consists of a reduced elbow joint with an adjustable mounting arm and a metal joint with rubber protecting border.

With the optional telescopic handle, the operator can easily connect the stacker to the upstanding tailpipe without having to climb on the vehicle.

APPLICATIONS

The stacker is intended to be used for the following applications: 

- To eliminate hazardous vehicle exhaust emissions with our vehicle exhaust capture and removal systems for the following segments: fire and emergency service stations as well as military facilities.

SPECIFICATIONS

■ Physical dimensions and properties	
Material	<ul style="list-style-type: none"> • elbow joint and mounting arm • zinc-plated steel • protecting border • EPDM rubber
Colour	silver/black
Weight	see remaining specifications
■ Ambient conditions	
Operating temperature	depends on the hose, refer to the hose datasheet
Max. relative humidity	80%
Outdoor use allowed	no
■ Where used	
The stacker can be used in combination with Plymovent fixed extractors, exhaust reels and railsystems.	
■ Scope of supply	
Stacker	
■ Options and accessories	
TH-90 telescopic handle	0000105249
■ Order information	
Article no.	see remaining specifications
Number/package	1
■ Shipping data	
Gross weight	45 kg
Packing dimensions	800 x 1200 x 600 mm
Harmonized Tariff Code	84213925

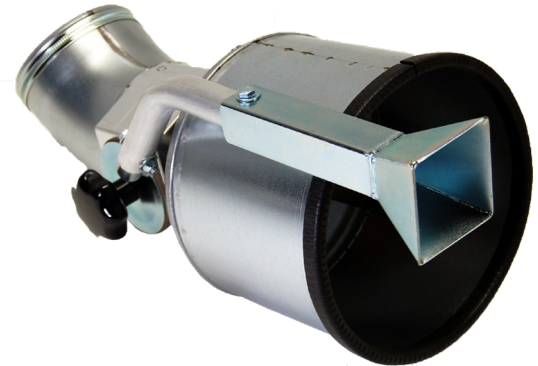

DIMENSIONS

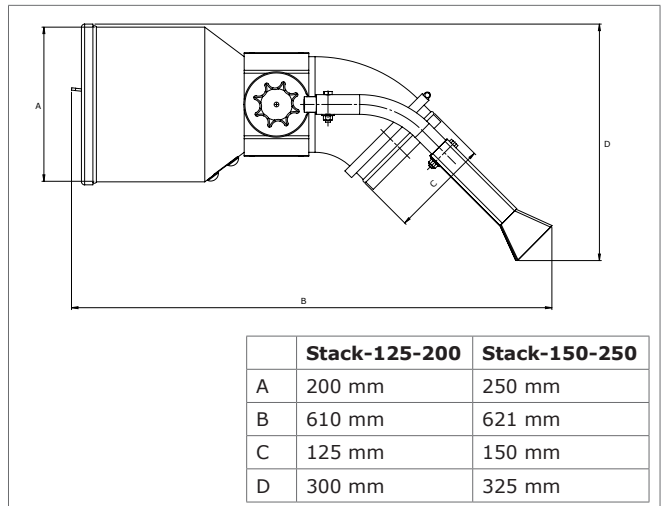

REMAINING SPECIFICATIONS

Description	Art. no.	Weight
Stack-125-200	0000111760	26 kg
Stack-150-250	0000111761	34 kg

Product type	Stacker
Article no.	see remaining specifications
Product category	nozzles
Version	260419/0

Always check the latest version on www.plymovent.com